

# TUXEDO DISTRIBUTORS, LLC

## TP15K

15,000LB CAPACITY TWO POST LIFT  
WITH OVERHEAD BEAM

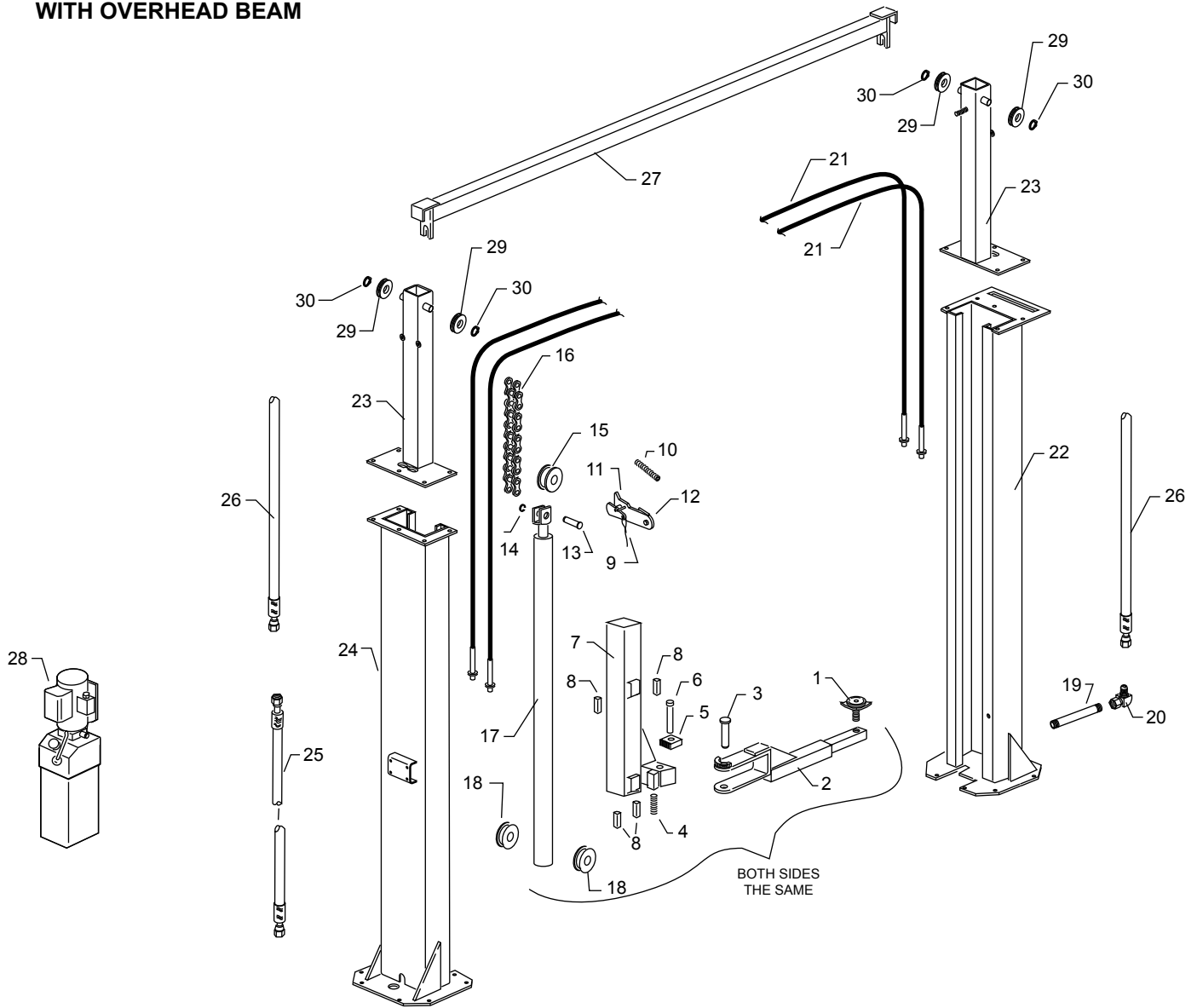

ILLUSTRATIONS ARE FOR REFERENCE ONLY AND ARE SUBJECT TO CHANGE WITHOUT NOTICE

ITEM	P/N	DESCRIPTION
1	TP15K-8000	ADAPTER BASE
2	TP15K-8001	ARM ASSEMBLY
3	TP15K-8002	ARM PIN
4	TP15K-8003	ARM RESTRAINT PIN
5	TP15K-8004	ARM RESTRAINT GEAR SMALL
6	TP15K-8005	ARM RESTRAIN SPRING
7	TP15K-8006	CARRIAGE
8	TP15K-8007	SLIDER BLOCK
9	TP15K-8008	LOCK RELEASE CABLE
10	TP15K-8009	LOCK RELEASE SPRING
11	TP15K-8010	LOCK RELEASE LEVER
12	TP15K-8011	LOCK PAWL
13	TP15K-8012	PULLEY PIN
14	TP15K-8013	PULLEY PIN "C" CLIP
15	TP15K-8014	CHAIN ROLLER
16	TP15K-8015	CHAIN

ITEM	P/N	DESCRIPTION
17	TP15K-8016	HYDRAULIC CYLINDER
18	TP15K-8017	CABLE SHEAVE
19	TP15K-8018	FITTING, STRAIGHT
20	TP15K-8019	FITTING, 90 DEGREE
21	TP15K-8020	EQUALIZER CABLE
22	TP15K-8021	COLUMN SLAVE (OFFSIDE)
23	TP15K-8022	COLUMN UPRIGHT
24	TP15K-8023	COLUMN PU SIDE (MAINSIDE)
25	TP15K-8024	HYDRAULIC HOSE (CYL TO PU)
26	TP15K-8025	HYDRAULIC HOSE (CYL TO CYL OVERHEAD)
27	TP15K-8026	OVERHEAD BEAM WELDMENT
28	PU-220VW	POWER UNIT, 220W W/KILL SWITCH
29	TP15K-8027	CABLE SHEAVE, UPRIGHT
30	TP15K-8028	"C"- CLIP