

TUXEDO DISTRIBUTORS, LLC

FP-14

14,000LB CAPACITY FOUR POST LIFT

FP-14A

14,000LB CAPACITY FOUR POST ALIGNMENT LIFT

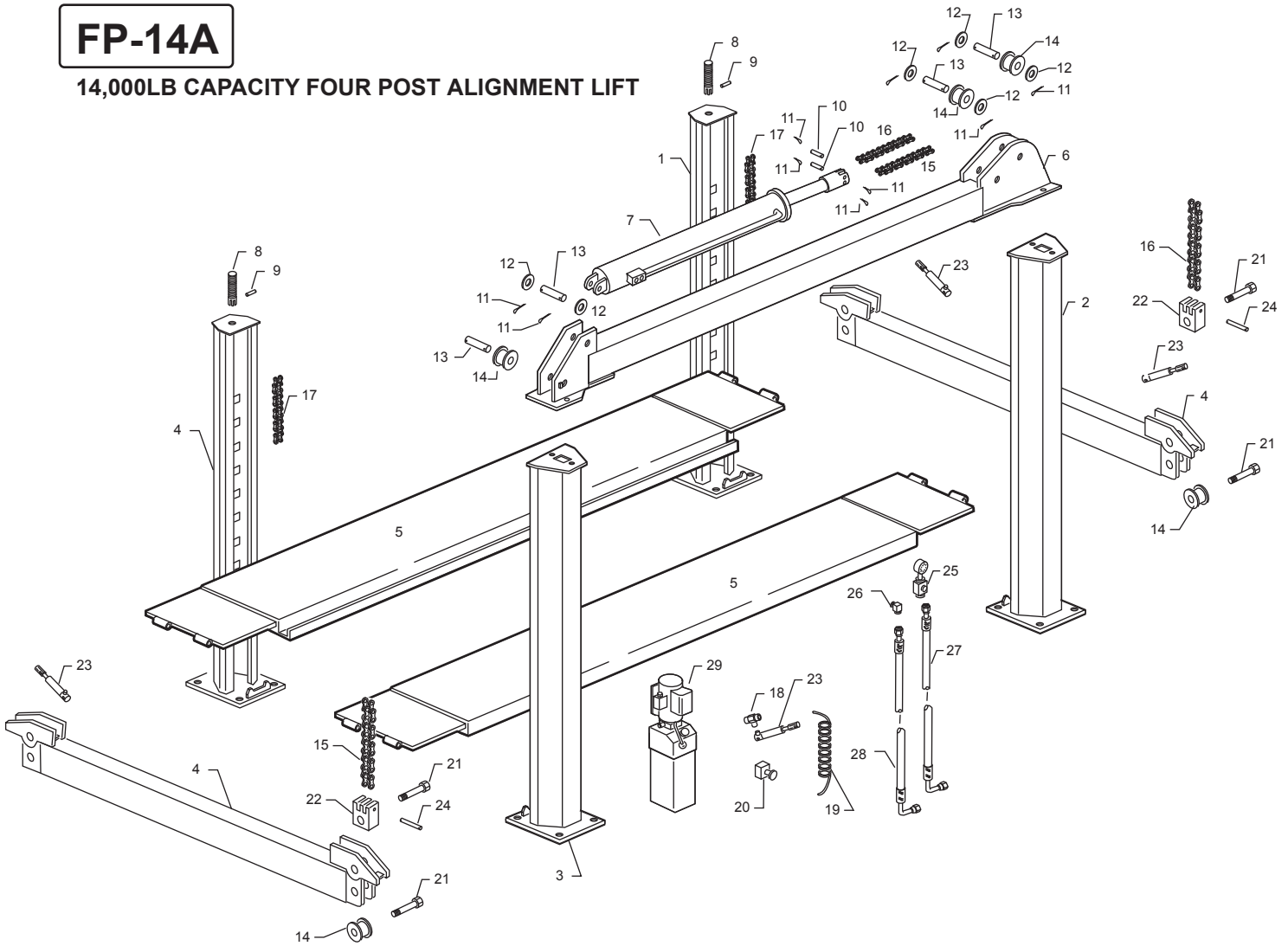

ILLUSTRATIONS ARE FOR REFERENCE ONLY AND ARE SUBJECT TO CHANGE WITHOUT NOTICE

ITEM	P/N	DESCRIPTION
1	FP14-5000	POST, OFFSIE RH / LH
2	FP14-5001	POST, MAINSIDE RH
3	FP14-5002	POST, MAINSIDE W/PU BRKT
4	FP14-5003	WELDMENT, CROSS BAR
5	FP14-5004	WELDMENT, TRACK
	FP14-5018	WELDMENT, ALIGNMENT TRACK
6	FP14-5005	WELDMENT, TOP RAIL
7	FP14-5006	CYLINDER, HYDRAULIC
8	FP14-5007	STUD, CHAIN ANCHOR
9	FP14-5008	PIN, CHAIN ANCHOR STUD
10	FP14-5009	PIN, ROLL CHAIN
11	FP14-5010	PIN, COTTER
12	FP14-5011	WASHER, FLAT
13	FP14-5012	SHAFT, ROLLER
14	FP14-5013	ROLLER, CHAIN
15	FP14-5014	CHAIN, CYLINDER TO CHAIN BLOCK

ITEM	P/N	DESCRIPTION
16	FP14-5015	CHAIN, CYLINDER TO PU CHAIN BLK
17	FP14-5016	CHAIN, OFFSIDE LEG TO MAINSIDE LEG
18	FP14-5017	TEE FITTING, AIRLOCK
19	FP14-5018	HOSE, SPRING AIR, PUSH BTN TO AIR CYL.
20	FP14-5019	BUTTON, AIR LOCK RELEASE
21	FP14-5020	BOLT, CHAIN BLOCK
22	FP14-5021	BLOCK, CHAIN
23	FP14-5022	CYLINDER, AIR LOCK
24	FP14-5023	PIN, CHAIN BLOCK ROLL
25	FP14-5024	GAUGE, HYDRAULIC CYLINDER
26	FP14-5025	FITTING, HYDRAULIC
27	FP14-5026	HOSE, HYDRAULIC, CYL GAUGE TO PU
28	FP14-5027	HOSE, HYDRAULIC, FITTING TO PU
29	FP14-5028	POWER UNIT