

**COATS
BADA**

AMMCO

520 Wheel Lift COATS



Installation Instructions Operating Instructions Safety Instructions Maintenance Instructions

READ these instructions before placing unit in service. KEEP these and other materials delivered with the unit in a binder near the machine for ease of reference by supervisors and operators.

Manual Part No.: 111929
Revision Date: 6/99 rev. 3

HENNESSY INDUSTRIES, INC.

P.O. Box 3002, 1601 J. P. Hennessy Drive, LaVergne, TN USA 37086 615/641-7533 800/688-6359

HENNESSY INDUSTRIES INC. Manufacturer of AMMCO®, COATS® and BADA® Automotive Service Equipment and Tools.

IMPORTANT SAFETY INSTRUCTIONS

1. Read and understand this manual and all on-machine labels before operating this equipment. Abuse and misuse will shorten the functional life.
2. Do not operate equipment if the equipment has been dropped or damaged until a qualified service technician has examined it.
3. To reduce the risk of fire, do not operate equipment in the vicinity of open containers of flammable liquids (i.e. gasoline).
4. Keep hair, loose clothing, fingers and all other body parts away from moving parts.
5. Use only as described in this manual. Use only manufacturer's recommended attachments.
6. ALWAYS WEAR SAFETY GLASSES. Everyday glasses only have impact resistant lenses; they are NOT safety glasses.
7. Keep guards and safety features in place and in working order.
8. Wear proper clothing. Safety toe, non-slip footwear and protective hair covering to contain hair are recommended. Do not wear jewelry, loose clothing, neckties, or gloves when operating the wheel lift.
9. Keep work area clean and well lighted. Cluttered and/or dark areas invite accidents.
10. Repair or replace any part that is damaged or worn and that may cause unsafe operation.
11. Never overload or stand on the wheel lift.
12. Do not allow untrained persons to operate machinery.

SAVE THESE INSTRUCTIONS

Table of Contents

Important Safety Instructions	ii
Definitions of Hazard Levels	1
Owner's Responsibility	1
Introduction	2
Specifications	2
Before You Begin	2
Safety Devices	2
Transport	2
Unpacking	2
Installation	3
Mounting	3
Workspace Requirements	3
Pneumatic Connection	4
Centering Setup	4
Operation	5
Control Identification	5
Adjustable Muffler	5
Layout of Functional Parts	5-6
Routine Maintenance	7
Moving the Machine	7
Storing	7
Troubleshooting	7
Parts List	8-9

Definitions of Hazard Levels

Identify the hazard levels used in this manual with the following definitions and signal words:

DANGER

Watch for this symbol:



It Means: Immediate hazards which will result in severe personal injury or death.

WARNING

Watch for this symbol:



It Means: Hazards or unsafe practices which could result in severe personal injury or death.

CAUTION

Watch for this symbol:



It Means: Hazards or unsafe practices which could result in minor personal injury or product or property damage.



Watch for this symbol! It means **BE ALERT!** Your safety, or the safety of others, is involved!



Owner's Responsibility



To maintain machine and user safety, the responsibility of the owner is to read and follow these instructions:

- Follow all installation instructions.
- Make sure installation conforms to all applicable Local, State, and Federal Codes, Rules, and Regulations; such as State and Federal OSHA Regulations and Electrical Codes.
- Carefully check the unit for correct initial function.
- Read and follow the safety instructions. Keep them readily available for machine operators.
- Make certain all operators are properly trained, know how to safely and correctly operate the unit, and are properly supervised.
- Allow unit operation only with all parts in place and operating safely.
- Carefully inspect the unit on a regular basis and perform all maintenance as required.
- Service and maintain the unit only with authorized or approved replacement parts.
- Keep all instructions permanently with the unit and all decals on the unit clean and visible.



Failure to follow danger, warning, and caution instructions may lead to serious personal injury or death to operator or bystander or damage to property. Do not operate this machine until you read and understand all the dangers notices, warnings and cautions in this manual. For additional copies of the warning labels or manuals or further information, contact:

Hennessy Industries, Inc.
P.O. Box 3002, 1601 J.P. Hennessy Drive
LaVergne, TN 37086-1982
(615) 641-7533 or (800) 688-6359

Introduction

The Coats wheel lift when positioned next to a wheel balancer can be used to lift car, motorcycle and van wheels (with diameters from 20.5" to 33.5" and weighing up to 175 lbs.) and center them automatically with the balancer stub shaft. Any other use is improper. Before beginning any kind of work on or with this machine, carefully read and understand the contents of these operating instructions.

Keep this manual near the machine and consult it as needed during operations.

Specifications

Working Pressure	115-145 psi
Minimum Wheel Diameter	20.5"
Maximum Wheel Diameter	33.5"
Maximum Wheel Weight	175 lbs.
Weight of the Lift	190 lbs.

Before you Begin

The shipment should be thoroughly inspected as soon as it is received. The signed bill of lading is acknowledgement by the carrier of receipt in good conditions of the shipment covered by our invoice. If any of the goods called for on this bill of lading are shorted or damaged, do not accept them until the carrier makes a notation on the freight bill of the shorted or damaged goods. Do this for your own protection.

NOTIFY THE CARRIER AT ONCE if any hidden loss or damage is discovered after receipt and ask the carrier to make an inspection. If the carrier will not do so, prepare a signed statement to the effect that you have notified the carrier (on a specific date) and that the carrier has failed to comply with your request.

IT IS DIFFICULT TO COLLECT FOR LOSS OR DAMAGE AFTER YOU HAVE GIVEN THE CARRIER A CLEAR RECEIPT.

File your claim with the carrier promptly. Support your claim with copies of the bill of lading, freight bill, invoice, and photographs, if available. Although COATS' responsibility ceases upon delivery of the shipment to the carrier, we will gladly assist in tracing lost shipments. Our willingness to assist in every possible manner does not make COATS responsible for collection of claims or replacement of lost or damaged materials. Shipping damage claims will not be handled under warranty.

Safety Devices

The Coats wheel lift is equipped with a pressure relief device (Fig. A) that prevents air supply pressures higher than 145 psi.

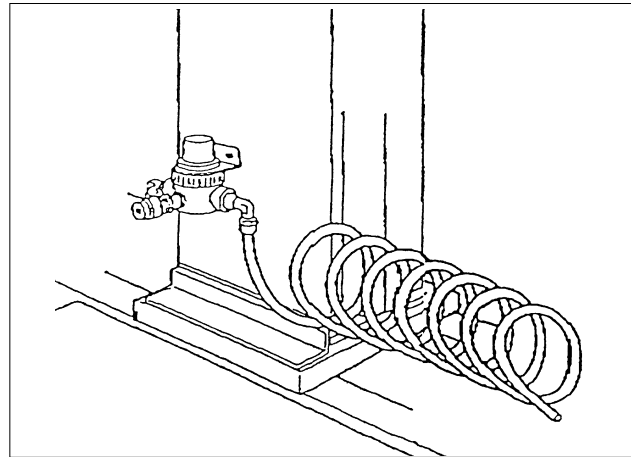

Figure A - Pressure Relief Device

This device comprises:

- a pressure relief valve factory set and locked at 145 psi.
- a maximum pressure valve factory set at 145 psi which cuts in if the relief valve fails.



WARNING Removing or tampering with these safety devices may lead to personal injury and damage to property

Transport

The Coats wheel lift is delivered packed in a crate. Move it with a fork lift truck inserting the forks under the crate as shown in Fig. B.

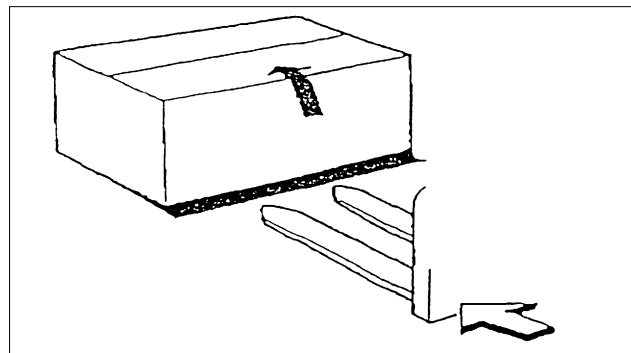

Figure B- Crate Transport

Overall packing size: 54" x 19" x 15.5"

Wheel lift gross weight: 200 lbs.

Unpacking

Once the packing material has been removed, check the machine visually for any signs of damage. Keep the packing materials out of the reach of children as they can be a source of danger.

Installation

Mounting

1. Remove the 4 screws, labeled item 1 in Fig. C, insert in the base, labeled item 2 in Fig. C.
2. Position the upright, labeled item 3 in Fig. C, on the base and secure it with the 4 screws.

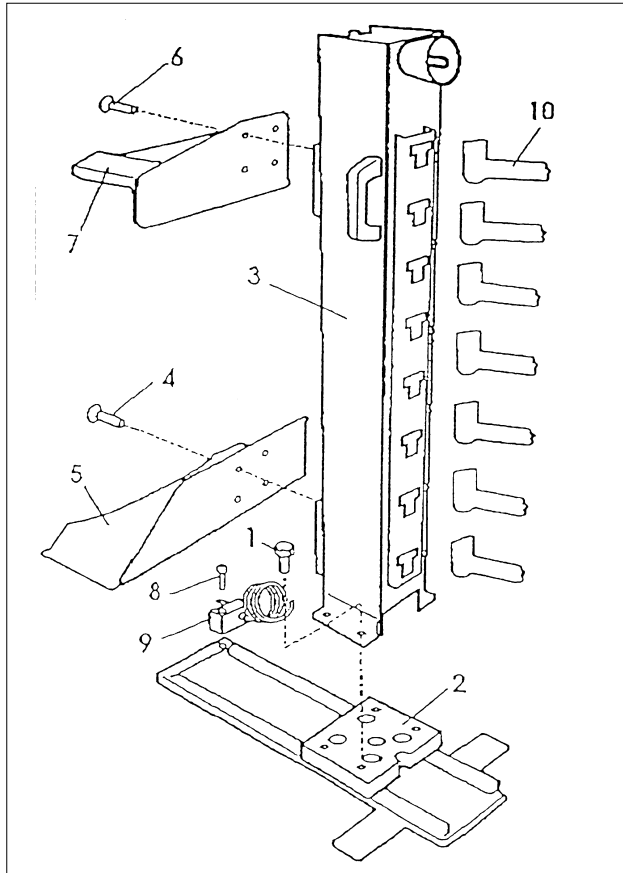

Figure C - Wheel Lift Installation Diagram

⚠ DANGER Use a sling for the upright (minimum length of 24") putting it under the upper wheel carrier, labeled item 4 in Fig. H, and inside the handle, labeled item 2 in Fig. H, as shown in Fig. L. Attach the ends of the sling to a hoist above the lift. Hoist and move the lift using hoisting equipment with adequate carrying capacity.

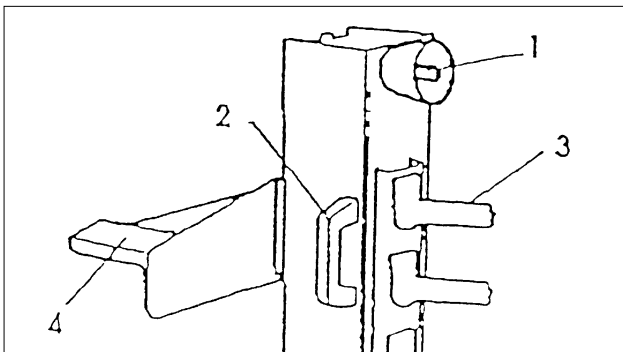

Figure H - Sling Position for Upright

3. Remove the 4 screws, labeled item 4 in Fig. C, and use them in the same holes to attach the lower wheel carrier, labeled item 5 in Fig. C.
4. Similarly, remove the 4 screws, labeled item 6 in Fig. C, and use them in the same holes to attach the upper wheel carrier, labeled item 7 in Fig. C.
5. Remove the screw, labeled item 8 in Fig. C, and use it in the same hole to mount the compressed air supply assembly, labeled item 9 in Fig. C.

Workspace Requirements

Position the lift near the wheel balancer (see Fig. D) so that:

1. When a wheel is on the lift, it is lined up with the balancer stub shaft.
2. The lift is positioned to allow:
 - the wheel to be loaded (when the upright is retracted)
 - the wheel to be moved against the stub shaft (when the upright is forward).

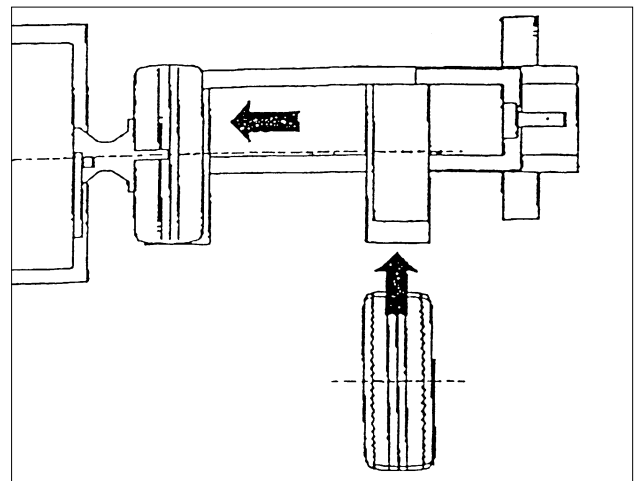

Figure D - Wheel Lift Installation Diagram

The Coats wheel lift must be attached to the floor. The base should be anchored to the floor using two normal metal expansion bolts ($\frac{3}{8}$ " x $2\frac{3}{4}$ ") to bolt the base to the floor. These bolts are packaged with the wheel lift. Be certain that these fasteners are correct for the location chosen.



WARNING If the lift is not to be used on concrete, other appropriate fasteners must be used.

Pneumatic Connection

Connect the air intake, labeled item 1 in Fig. E, to the compressed air system with a working pressure of 115-145 psi. Use a compressed air hose with an inside diameter of $\frac{1}{4}$ " - $\frac{3}{8}$ ".

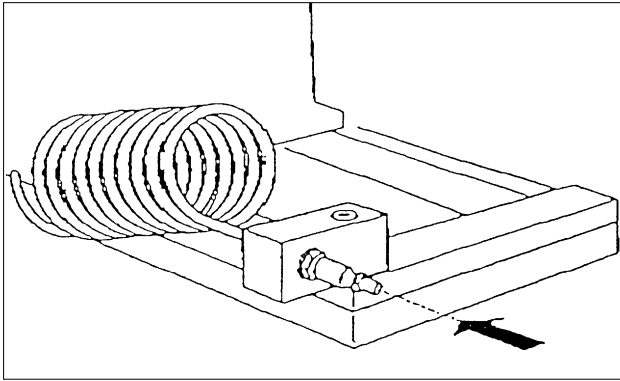

Figure E- Connect the Air Intake



Make sure the air hose is free of the track area. If the air hose is damaged, the lift may descend unexpectedly.

Centering Setup

If necessary, centering performance can be adjusted so that the wheel is lifted to the precise heights of the balancer stub shaft.

Follow these steps:

1. Mount a wheel on the lift and raise it as detailed in the "Operating" section on page seven of this manual.
2. Use two 17mm wrenches to adjust the nuts, labeled item 1 in Fig. F, until the wheel is centered with the balancer stub shaft.
3. Tighten the nuts against each other.

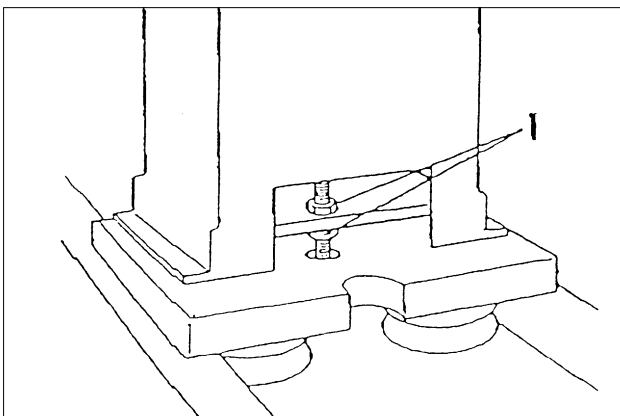

Figure F- Center Wheel with Balancer Stud Shaft

Operation

Control Identification

Toggle switch (Fig. G) is used to raise and lower the wheel:

- move the switch upward (Position 1) to clamp the wheel and raise it until the wheel is automatically centered with the balancer stub shaft.
- move the switch to the center (Position 0) to release the wheel from the clamps so that the carriage can be moved backwards (do this only when the wheel has been clamped onto the balancer stub shaft).
- move the switch downward (Position 2) to lower the wheel clamps to load or unload a wheel.

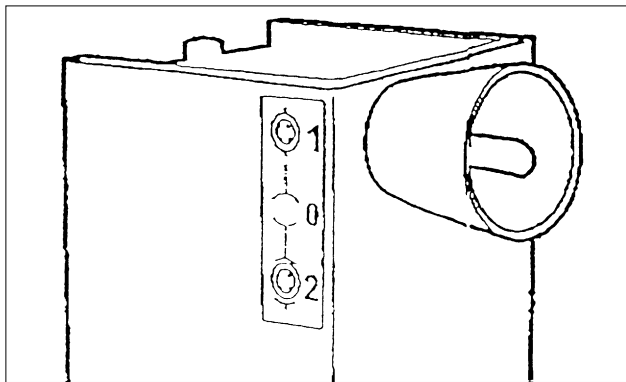

Figure G- Toggle Switch

Adjustable Muffler



Disconnect the air supply line before attempting any adjustment.

This wheel lift has been equipped with an adjustable muffler. The purpose of this muffler is to allow the operator to control the rate at which the wheel descends. It is recommended that the muffler be set as follows:

1. Turn the muffler clockwise until it is finger tight against the valve.
2. Turn the muffler counterclockwise two revolutions.

This has been preset at the factory. The further the muffler is adjusted counterclockwise the faster the wheel will descend. Caution should be used when setting the descent rate. The muffler can fall off if adjusted too far. The lift **MUST** have the muffler in place to operate.

Layout of Functional Parts (Fig. H)

1. Toggle Switch
2. Carriage Moving Handle
3. Flange and Cone Holders
4. Upper Wheel Clamp
5. Lower Wheel Clamp
6. Upright
7. Base
8. Compressed Air Connector

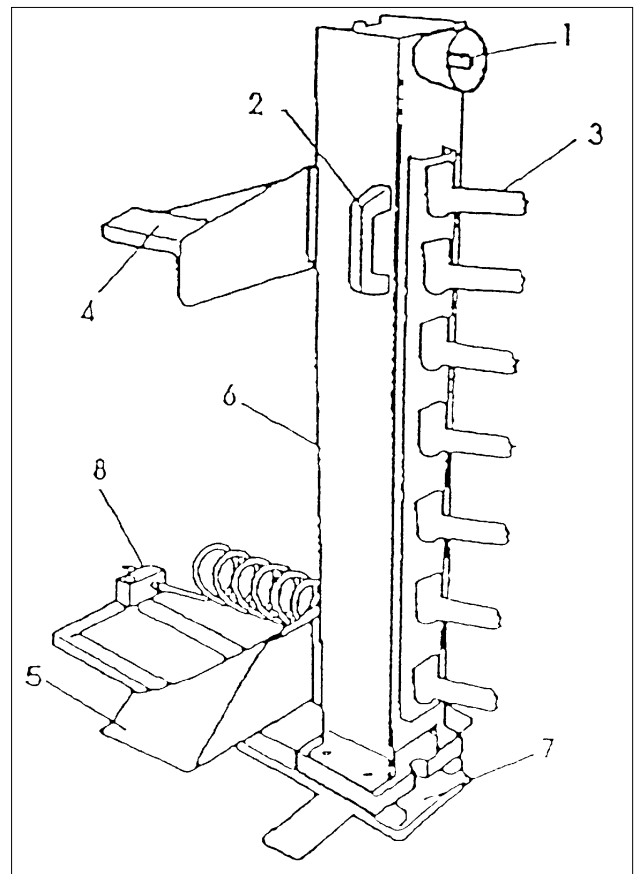

Figure H- Wheel Lift Functional Parts



Before moving the upright, make sure the track area is clear of debris.

1. Use the handle, labeled item 2 in Fig. H, to move the upright, labeled item 6 in Fig. H, back to create the space needed to load the wheel.
2. Move the toggle switch, labeled item 1 in Fig. H, down (Position 2).
3. Roll the wheel onto the lower wheel clamp, labeled item 5 in Fig. H.

4. Move the toggle switch upward (Position 1). The wheel will be clamped between the upper and lower wheel clamps and raised to the height of the balancer stub shaft.



During this operation, do not put your hands on the top of the wheel. Your

hands could be pinched between the wheel and the clamp.

5. Use the handle, labeled item 2 in Fig. H, to move the upright, labeled item 6 in Fig. H, forward until the wheel is on the balancer stub shaft and ready to be mounted on the balancer.
6. Secure the wheel to the balancer using suitable mounting adapters.
7. Move the toggle switch, labeled item 1 in Fig. H, to the center (Position 0) to release the wheel from the clamps.
8. Move the upright, labeled item 6 in Fig. H, backward to free the wheel balancer work area.
9. Balance the wheel.
10. Move the upright, labeled item 6 in Fig. H, forward until the wheel clamps, labeled items 4 & 5 in Fig. H, are positioned on the wheel.
11. Move the toggle switch up (Position 1) to clamp the wheel between the wheel clamps.



During this operation, do not put your hands on the top of the wheel. Your

hands could be pinched between the wheel and the clamp.

12. Remove the wheel from the balancer stub shaft.
13. Move the upright backward to create the space needed to unload the wheel.
14. Move the toggle switch, labeled item 1 in Fig. H, down (Position 2) to lower the wheel and release it from the clamps.
15. Turn the wheel by hand until it comes out of the lower wheel clamp.

Routine Maintenance

The Coats Wheel lift does not need any special routine maintenance. To ensure correct functional performance and a long working life, lubricate the following surfaces once a month with a silicone spray lubricant:

- the hex bar along which the clamps run, labeled items 4 & 5 in Fig. H
- the hex runners inside the base
- the base wheels

When lubricating the machine also take the time to clean the track that runs between the hex bars. Wheel weights, debris, and hand tools can get between the track.

Moving the Machine

Follow these steps if the lift has to be moved.

1. Disconnect the lift from the compressed air supply.
2. Unbolt the lift from the floor.
3. Move the upright, labeled item 6 in Fig. H, to its limit stop.
4. Use a sling for the upright (minimum length 24") putting it under the upper wheel clamp, labeled item 4 in Fig. H, and inside the handle, labeled item 2 in Fig. H, as shown in Fig. L.
5. Attach the ends of the sling to a hoist above the lift. Hoist and move the lift using hoisting equipment with adequate carrying capacity.

Storing

If the lift has to be stored for a long time:

1. Disconnect the lift from the compressed air supply.
2. Grease thoroughly:
 - the hex bar along which the clamps run, labeled items 4 & 5 in Fig. H
 - the hex runners inside the base
 - base wheels
3. Cover the lift with a plastic sheet.

Troubleshooting

Problem: When the toggle switch is moved upwards the wheel is not clamped and raised.

Causes: Either there is not enough pressure in the compressed air system or the air supply lines are crushed or damaged.

Solution: Increase the supply air pressure to no more than 145 psi and/or replace damaged air lines.

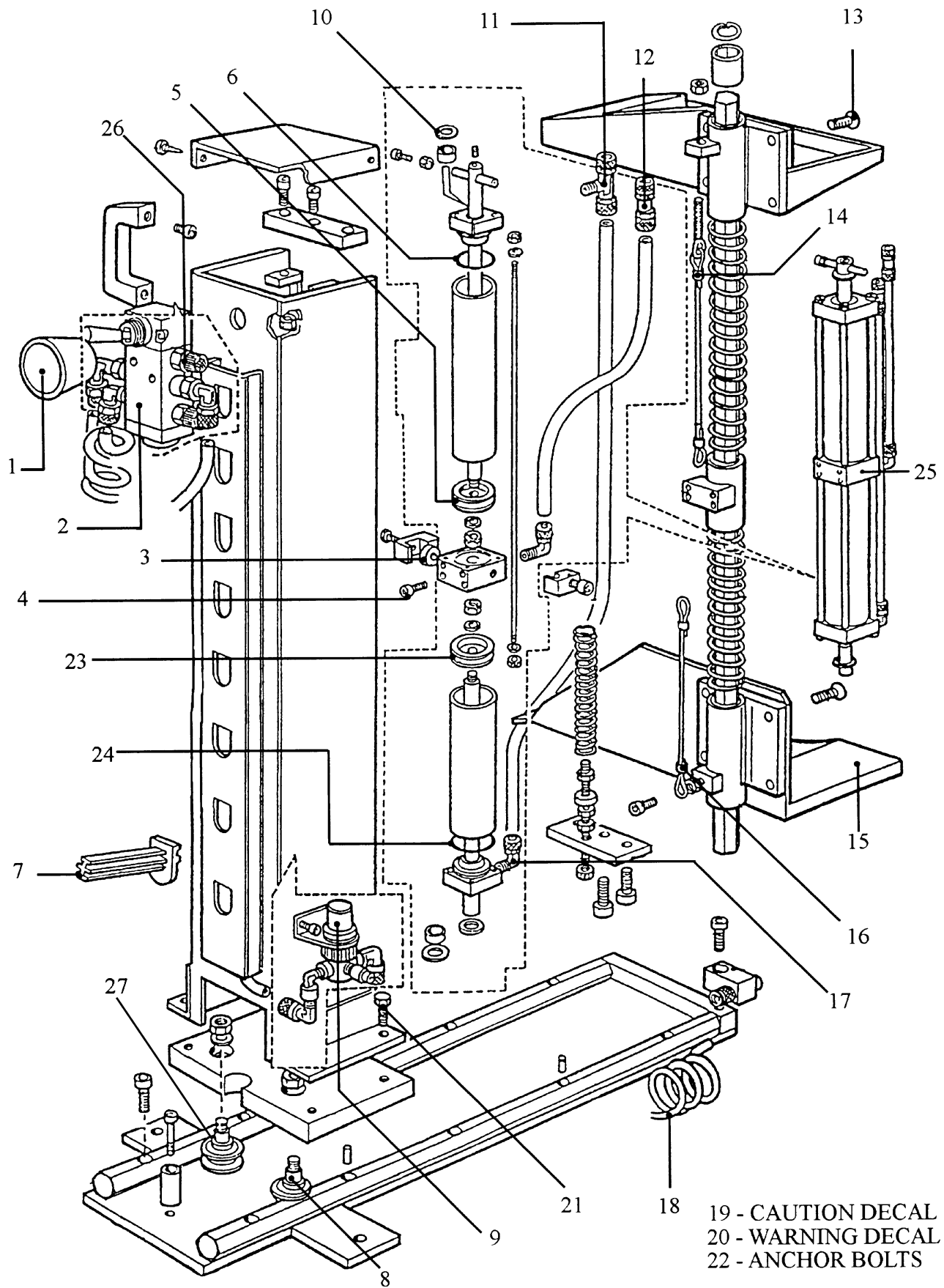

<u>ITEM #</u>	<u>PART #</u>	<u>QTY.</u>	<u>DESCRIPTION</u>
1	111939	1	Plastic Switch Cover
2	112434	1	Pneumatic Valve Complete
3	111940	1	Pulley
4	112432	4	Screw - M6 x 20
5	112430	1	Piston Gasket 50mm
6	112429	1	"O" Ring Seal 144mm
7	111945	5	Coats Accessory Pegs
8	112431	2	Coaxial Roller Complete (Fixed)
9	112433	1	Air Regulator Complete
10	112439	2	Lipped Gasket
11	112436	1	Tee Fitting $\frac{1}{8}$ $\frac{1}{8}$ 6-4
12	112437	1	Double Union Fitting 6-4 x 6-4
13	111941	8	Screw
14	111942	1	Adjustable Cable
15	111943	1	Lower Wheel Clamp
16	111944	1	Cable
17	112435	2	Ell Fitting $\frac{1}{8}$, 6-4
18	112438	1	Pneumatic Hose
19	111927	1	Caution Decal
20	111938	1	Warning Decal
21	111946	4	Screw
22	111933	2	Anchor Bolts
23	111955	1	Piston Gasket
24	111956	1	"O" Ring Seal
25	111957	1	Cylinder Assembly
26	111958	1	Muffler
27	112832	2	Coaxial Roller Complete (Adjustable)

