

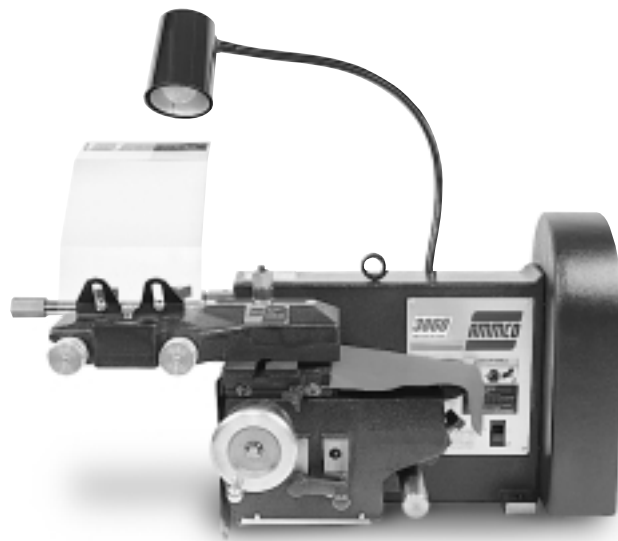

# 3850, 3860 Drum & Disc Brake Lathes



## Installation Instructions Operating Instructions Safety Instructions Maintenance Instructions

READ these instructions before placing unit in service. KEEP these and other materials delivered with the unit in a binder near the machine for ease of reference by supervisors and operators.

**HENNESSY INDUSTRIES, INC.**

1601 J. P. Hennessy Drive, LaVergne, TN USA 37086-3565 615/641-7533 800/688-6359

HENNESSY INDUSTRIES INC. Manufacturer of AMMCO®, COATS® and BADA® Automotive Service Equipment and Tools.

Manual Part No.: 929250 09

Revision: 05/01

# Brake Lathes

# Contents

## Table of Contents

<b>Safety Notices and Decals</b> .....	<b>iv</b>
<b>Warning</b> .....	<b>iv</b>
Cautions and Dangers .....	iv
<b>Owner's Responsibility</b> .....	<b>v</b>
<b>Definitions of Hazard Levels</b> .....	<b>v</b>
<b>Important Safety Instructions</b> .....	<b>vi</b>
<b>Before You Begin</b>	
Receiving .....	1
Electrical Requirements .....	1
Installation .....	2
Preparation for Use .....	2
Specifications .....	2
Principle Operating Parts .....	3
<b>Operating Instructions</b>	
Negative and Positive Rake Tooling .....	3
Starting the Lathe .....	4
Selecting Feed Drive Direction - Rotor or Drum ..	4
Reading the Drum Depth-of-Cut Micrometer Dial ..	5
Arbor Installation .....	5
Mounting Drums .....	6
Reconditioning Brake Drums .....	6
Mounting Brake Rotors .....	10
Reconditioning Brake Rotors .....	11
<b>Maintenance and Service</b> .....	<b>14</b>
Lubrication .....	14
Cleaning .....	15
Arbor and Adapter Care .....	15
Gib Adjustment .....	16
3860 Drum Tool Bar Adjustment .....	17

# Safety

## Safety Notices and Decals

For your safety, and the safety of others, read and understand all of the safety notices and decals included here and on the unit.

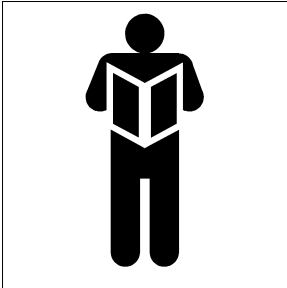

**Read entire manual before installing, operating, or servicing this equipment.**

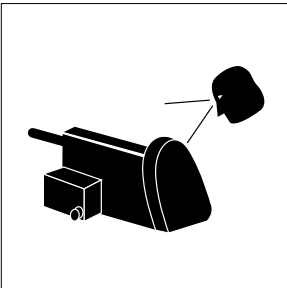

**Proper maintenance and inspection is necessary for safe operation.**



**Do not operate a damaged lathe.**

## Warning

This equipment incorporates parts such as snap switches and power receptacles which tend to produce arcs or sparks. Therefore, when located in a service facility, the unit should be in a room or enclosure provided for the purpose, or should be at least 18" or more above floor to minimize the risk of igniting fuel vapors.

## Cautions and Dangers

1. Eye and face protection requirements:

"Protective eye and face equipment is required to be used where there is a reasonable probability of injury that can be prevented by use of such equipment." OSHA 1910.133 (a).

Protective goggles, safety glasses, or a face shield must be provided by the purchaser/user and worn by the operator of the equipment. Make sure all eye and face safety precautions are followed by the operator(s). Keep bystanders out of the area.

2. Do not remove any safety equipment, belt guards, or shortcut controls or operations.
3. Make sure drums and rotors are properly and squarely mounted before starting lathe, and that all parts are secure.
4. Do not wear loose clothing, jewelry, or gloves when operating or working around a lathe.
5. Do not overload the lathe. Read and understand the lathe specifications. Overloading is poor machine tool practice, shortens the life of the lathe, and could cause a failure resulting in personal injury.



**Failure to follow danger, warning, and caution instructions may lead to serious personal injury or death to operator or bystander or damage to property. Do not operate this machine until you read and understand all the dangers, warnings and cautions in this manual. For additional copies of either, or further information, contact:**

### **Hennessy Industries, Inc.**

1601 J.P. Hennessy Drive  
LaVergne, TN 37086-3565  
(615) 641-7533 or (800) 688-6359  
[www.Hennessy-Ind.com](http://www.Hennessy-Ind.com)

# Safety

## Owner's Responsibility

To maintain machine and user safety, the responsibility of the owner is to read and follow these instructions:

- Follow all installation instructions.
- Make sure installation conforms to all applicable Local, State, and Federal Codes, Rules, and Regulations; such as State and Federal OSHA Regulations and Electrical Codes.
- Carefully check the unit for correct initial function.
- Read and follow the safety instructions. Keep them readily available for machine operators.
- Make certain all operators are properly trained, know how to safely and correctly operate the unit, and are properly supervised.
- Allow unit operation only with all parts in place and operating safely.
- Carefully inspect the unit on a regular basis and perform all maintenance as required.
- Service and maintain the unit only with authorized or approved replacement parts.
- Keep all instructions permanently with the unit and all decals/labels/notices on the unit clean and visible.
- Do not override safety features.

## Definitions of Hazard Levels

Identify the hazard levels used in this manual with the following definitions and signal words:

### DANGER

Watch for this symbol:



It Means: Immediate hazards, which will result in severe personal injury or death.

### WARNING

Watch for this symbol:



It Means: Hazards or unsafe practices, which could result in severe personal injury or death.

### CAUTION

Watch for this symbol:



It Means: Hazards or unsafe practices, which may result in minor personal injury or product or property damage.



Watch for this symbol! It means BE ALERT! Your safety, or the safety of others, is involved!

<b>⚠ CAUTION ⚠</b> Prevent accidents and injury, read and follow instructions.		
<ol style="list-style-type: none"><li>1. Read and follow instructions.</li><li>2. Always wear eye protection, avoid loose clothing and jewelry.</li><li>3. Keep all guards, shields, and covers in place and in working order.</li><li>4. Keep bystanders out of work area.</li><li>5. Unplug unit from power source before servicing or adjusting.</li><li>6. Maintain unit properly, keep work surfaces and work area clean.</li></ol>		

# IMPORTANT SAFETY INSTRUCTIONS

Before operating the lathe, review the warning information on the lathe and the cautions, warnings and dangers in this manual. Also review the following general safety instructions. Failure to follow safety instructions could result in personal injury to operator or bystanders and damage to the lathe or personal property.

## READ ALL INSTRUCTIONS

When using your garage equipment, basic safety precautions should always be followed, including the following:

- 1.** Keep guards in place and in working order.
- 2.** Remove adjusting keys and wrenches from the tool before turning it on. Make this a habit.
- 3.** Keep work area clean and well lighted. Cluttered areas and benches invite accidents.
- 4.** To reduce the risk of fire, do not operate equipment in the vicinity of open containers of flammable liquids (gasoline).
- 5.** Adequate ventilation should be provided when working on operating internal combustion engines.
- 6.** Care must be taken as burns can occur from touching hot parts.
- 7.** Do not operate equipment with a damaged cord or if the equipment has been dropped or damaged—until it has been examined by a qualified serviceman.
- 8.** If an extension cord is necessary, a cord with a current rating equal to or more than that of the equipment should be used. Cords rated for less current than the equipment may overheat. Care should be taken to arrange the cord so that it will not be tripped over or pulled.
- 9.** To reduce the risk of electric shock, do not use on wet surfaces or expose to rain.
- 10.** Keep children away. All bystanders should be kept completely away from the work area.
- 11.** Make the workshop kid-proof. Use padlocks and master switches, and remove starter keys.
- 12.** Don't force a tool. It will do the job better and safer at the rate for which it was designed.
- 13.** Use the right tool. Don't force a tool or an attachment to do a job for which it was not designed.
- 14.** Dress properly. Keep hair, loose clothing, neckties, shop rags, jewelry, fingers, and all parts of body away from moving parts. Non-slip footwear is recommended.
- 15.** ALWAYS WEAR SAFETY GLASSES. Everyday eye-glasses only have impact resistant lenses, they are NOT safety glasses. Safety glasses, goggles, or a face shield will help protect the operator from injury. Use a face shield and dust mask during dusty operations.
- 16.** Secure the work properly to the unit for setup and tool bit positioning. Do not attempt to hold a drum or rotor steady on the arbor with your hands. Both hands must be free to operate unit.
- 17.** Don't overreach. Keep proper footing and balance at all times when lathe is in operation or when working around the unit.
- 18.** Maintain tools with care. Keep tools sharp and clean for best and safest performance. Follow instructions for lubricating and changing accessories.
- 19.** Remove power from the unit and disconnect tools before servicing and when changing accessories such as blades, bits, cutters, etc. Follow lock-out and tag-out procedures as required.
- 20.** Avoid unintentional starting. Make sure the switch is in the OFF (O) position before plugging the machine in or performing any maintenance or service work.
- 21.** Use of improper accessories may cause risk of injury to operator or bystanders. Use only as described in this manual. Use only manufacturer's recommended attachments.
- 22.** Never stand or lean on a lathe. Serious injury could occur if the lathe is tipped or if the cutting tool is unintentionally contacted.
- 23.** Check damaged parts carefully. Before further use of the lathe, a guard or other part that is damaged should be carefully checked. Immediately replace all damaged, missing, or non-functional parts. Check for alignment of moving parts, binding of moving parts, breakage of parts, mounting, and any other conditions that may affect operation. Guards and other parts that are damaged should be properly repaired or replaced before lathe is used again.
- 24.** Always feed the work into a blade or cutter and against the direction of rotation. Cutters and tool bits are designed to cut from the inside of a drum or rotor to the outer edge. Do not attempt to cut from the outside edge in to the center.
- 25.** Never leave tools running unattended. Turn the power off. Don't leave the tool until it comes to a complete stop.
- 26.** Never use compressed air to blow the tool clean. Chips and dust may be driven between machined parts and into bearings, causing undue wear. They may also contact persons in the area causing personal injury.
- 27.** Operate the lathe in the proper environment. The lathe incorporates parts such as snap switches and power receptacles which tend to produce arcs or sparks. Therefore, when located in a garage, the unit should be in a room or enclosure provided for the purpose, or should be at least 18" or more above the floor to minimize the risk of igniting fuel vapors.

## SAVE THESE INSTRUCTIONS

# Brake Lathes

## Before You Begin

### Receiving

The shipment should be thoroughly inspected as soon as it is received. The signed bill of lading is acknowledgement by the carrier of receipt in good condition of shipment covered by our invoice.

If any of the goods called for on this bill of lading are shorted or damaged, do not accept them until the carrier makes a notation on the freight bill of the shorted or damaged goods. Do this for your own protection.

NOTIFY THE CARRIER AT ONCE if any hidden loss or damage is discovered after receipt and request the carrier to make an inspection. If the carrier will not do so, prepare a signed statement to the effect that you have notified the carrier (on a specific date) and that the carrier has failed to comply with your request.

IT IS DIFFICULT TO COLLECT FOR LOSS OR DAMAGE AFTER YOU HAVE GIVEN THE CARRIER A CLEAR RECEIPT.

File your claim with the carrier promptly. Support your claim with copies of the bill of lading, freight bill, invoice, and photographs, if available.

Although AMMCO's responsibility ceases upon delivery of the shipment to the carrier, we will gladly assist in tracing lost shipments. Our willingness to assist in every possible manner does not make AMMCO responsible for collection of claims or replacement of lost or damaged materials. Shipping damage claims will not be handled under warranty.

### Electrical Requirements

The lathe must be properly grounded to protect the operator from shock. The lathe is equipped with an approved 3-conductor cord and a 3-prong grounding type plug to fit the proper grounding-type receptacle. Should an extension cord be required, use 3-conductor cords with 3-prong grounding plug and 3-prong grounding receptacle properly rated to handle this electrical power tool only. Do not modify a cord or plug to match a receptacle; have a qualified electrician install an appropriate outlet to match the lathe requirements. Repair or replace any worn or damaged power cords immediately.

The lathe requires a single-phase power source of 115 VAC ( $\pm 10\%$ ), 60 Hz, fused at 15 A for proper operation.

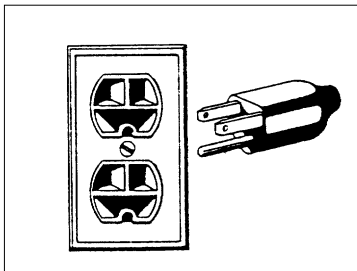

Figure 1 - Power Cord Plug and Receptacle

# Brake Lathes

## Installation

- 1.** Assemble bench according to the instructions provided. Tighten all fasteners securely.
- 2.** After assembly, the bench should be leveled and bolted down with 3/8 or 7/16 inch bolts or lag screws.
- 3.** Unbolt the lathe from the shipping pallet. Lift the lathe onto the bench using the eye bolt located on top of the lathe. Do not lift the lathe by the motor, pulley cover, crossfeed endcap, or leadscrew protective tube on the rear of the unit.
- 4.** Bolt the lathe to the bench with the hardware provided. Tighten fasteners securely.
- 5.** Remove any packing materials and protective wrapping from the lathe and components.
- 6.** Make sure lathe is turned off (switch in "O" position). Plug lathe into a properly installed and grounded outlet that matches the lathe plug.
- 7.** Clear the area and turn lathe on. Check for proper operation (motor and spindle rotation).

## Preparation for Use

- 1.** Inspect all adapters and accessories for burrs, nicks, or other damage.
- 2.** Clean accessories with a vaporizing solvent.
- 3.** Apply a light film of oil to all adapters to protect their machined surfaces from rust. Refer to the maintenance section for more information.

## Specifications

Overall Lathe Height . . . . .	16.5 in
Spindle to Floor (on AMMCO bench) . . . . .	.39.625 in
Spindle Speed (full load) . . . . .	175 RPM
Rotor Slide Feed Rate . . . . .	.0.0013 in/rev.
Drum Slide Feed Rate . . . . .	.0.0026 in/rev.
Micrometer Graduations . . . . .	.0.002 in
Max. Brake Rotor Diameter . . . . .	.21.5 in
Max. Brake Rotor Thickness . . . . .	.1.75 in
Min. Brake Drum Diameter . . . . .	.6.0 in
Max. Brake Drum Diameter . . . . .	.30.0 in
Max. Brake Drum Depth . . . . .	.6.0 in
Max. Load, 1 inch arbor . . . . .	.100 lbs
Max. Load, 1-7/8 inch arbor . . . . .	.200 lbs
Spindle Motor . . . . .	.1 HP
Electrical Requirements . . . . .	.115 VAC, 60 Hz
Single-Phase, Fused at 15A	
Lathe Weight (lathe only) . . . . .	.452 lbs
Floor Space (on opt. bench) . . . . .	.33.5 in W x 31 in D



# Brake Lathes

## Principal Operating Parts

### Know Your Unit

Compare this illustration with the unit before placing it into service. Maximum performance and safety will be obtained only when all persons using the unit are fully trained in its parts and operation. Each user should learn the function and location of all controls. Prevent accidents and injuries by ensuring the unit is properly installed, operated, and maintained.

- A** Work Light
- B** T-Bolt and Self-Aligning Hex Nut
- C** Drive Motor (not seen in drawing)
- D** 1" Arbor
- E** Arbor Nut
- F** Power Cord
- G** Twin Cutter
- H** Feed Handwheel
- I** Feed Button
- J** Feed Engagement Lever
- K** Depth-of-Cut Dial
- L** Slide Lock Knob
- M** Drive Belt Assembly Cover
- N** Power Panel (with ON/OFF Switch)
- O** Tool Slide
- P** Crossfeed

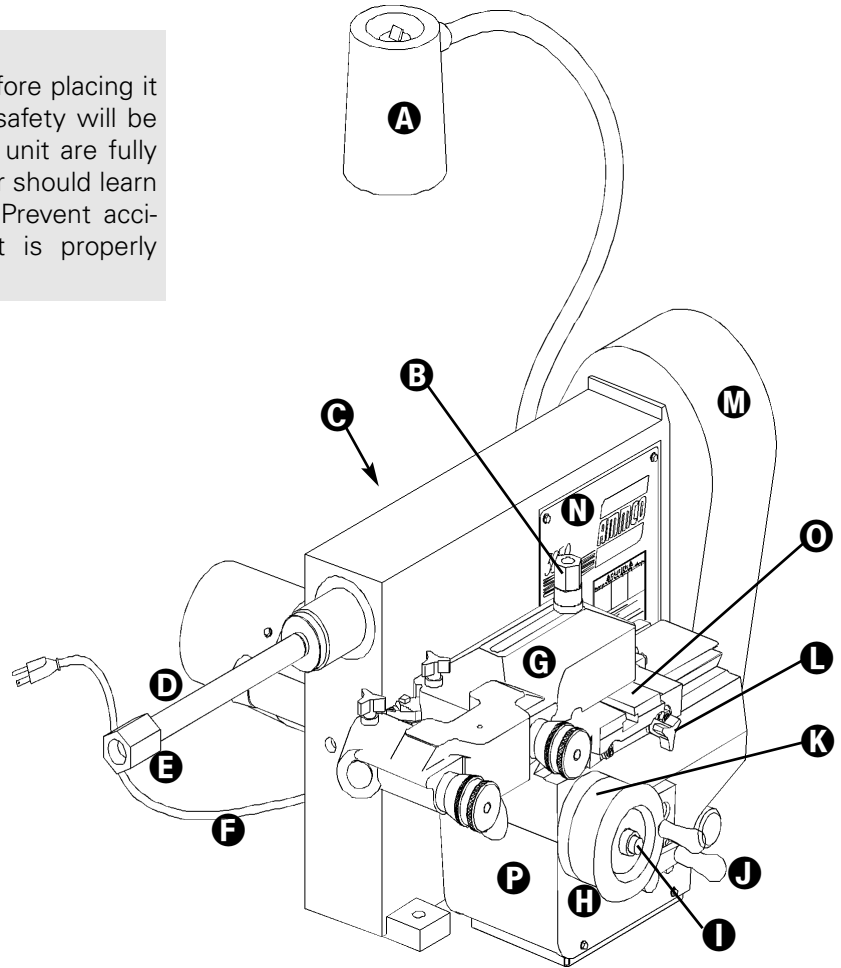

## Operating Instructions

### Negative and Positive Rake Tooling

3850		3860
BLACK	HOLDER	SILVER
POSITIVE	RAKE	NEGATIVE
6918	BIT	6914
0.005	MIN. CUT DEPTH	0.002

**Making shallow cuts of less than .005 inches greatly reduces the effective life of a positive rake tool bit. Shallow cutting does not transfer heat effectively from the bit to the rotor or drum, and reduces the life of the bit. Shallow cuts also do not allow the bit to dig enough, and may cause the bit to break.**

A negative rake tool bit angles downward from the tool bit holder towards the brake surface. A positive rake tool bit angles upwards from the holder towards the brake surface (figure 1).

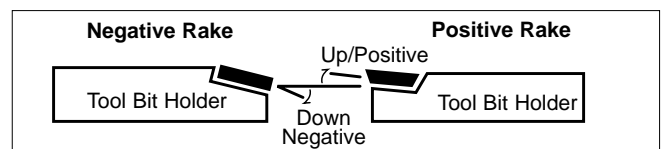

Figure 1 - Negative Rake Compared to Positive Rake

**Note: Do not** use positive bits on negative holders or negative bits on positive holders!

# Brake Lathes

## Starting the Lathe

The switch on the power panel turns the lathe on (I).



**Read and follow all safety instructions.**

## Selecting Feed Drive Direction - Rotor or Drum

Selecting the rotor setting allows the crossfeed to move in and out – moving the tool bit across the face of the rotor. Selecting the drum setting allows the tool slide to move left and right – moving the tool bit into and out of the drum. Always select setting with the feed drive disengaged. Familiarize yourself with the settings and movement of the feed:

**1.** Move the feed engagement lever down to disengage the feed.

**2.** Select the rotor setting by pressing the button in the center of the handwheel and moving the entire handwheel inward toward the lathe. It will seat into position and “pop” the button back out.

**3.** Turn the handwheel and notice the direction of feed travel. Turn the handwheel clockwise to move the crossfeed inward toward the lathe – into the center of a mounted rotor. Turn the handwheel counterclockwise to move the crossfeed away from the lathe – to the outer edge of a mounted rotor.

**4.** To select the drum setting, press the button in the center of the handwheel and pull the handwheel out. It will seat into position and “pop” the button back out.

**5.** Turn the handwheel and notice the direction of feed travel. Turn the handwheel clockwise to move the tool slide to the left – into the center of a mounted drum. Turn the handwheel counterclockwise to move the tool slide to the right – out of a mounted drum.

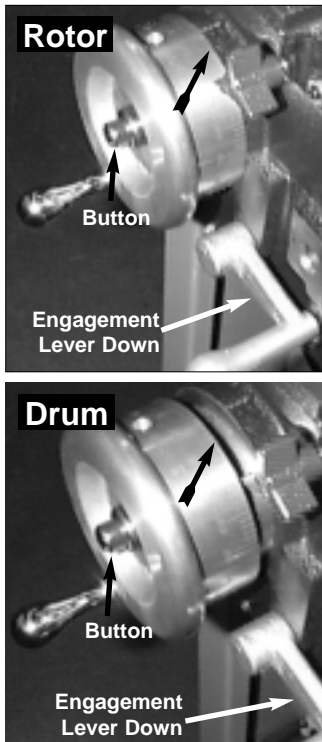
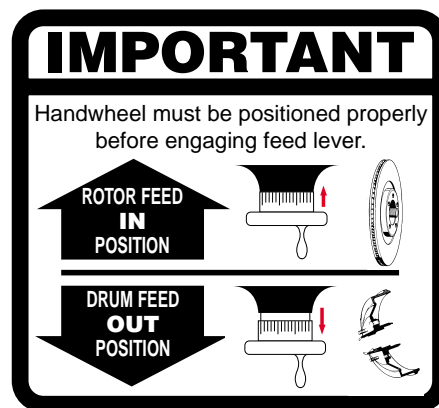

Figure 2 - Selecting Rotor and Drum settings on the Feed



**Note:** Look for this plate on the lathe. It has been placed on the unit to assist you while working with the lathe.

Notice also that rotor and drum positions are indicated on the handwheel with arrows pointing inward and outward.

# Brake Lathes

## Reading the Drum Depth-of-Cut Micrometer Dial

The drum depth-of-cut micrometer dial is located on the hand-wheel. The dial has an inch scale (metric on export models) and is used to select the amount of material to be cut from the inside drum diameter.

**(3850 ONLY)** The divisions on the handwheel inch scale are equivalent to 0.002". A 0.010" cut (five micrometer divisions) from an 8" drum will result in a refinished diameter of 8.010".

**(3860 ONLY)** The divisions on the micrometer dial of the adjustable drum boring bar indicate actual depth of cut. A 0.010" cut (five micrometer divisions) from an 8" drum will result in a refinished diameter of 8.020".

## Arbor Installation

The 1" arbor shipped with the lathe has been carefully matched to the spindle of the lathe during final assembly and testing. Witness marks have been etched onto the arbor and spindle for repeatable, precise alignment. This controls arbor runout ( $\leq 0.001$ "") when changing arbors. New arbors should be indicated and marked.

The witness marks should be carefully aligned when installing the arbor. A true running arbor is essential to professional quality brake drum and rotor reconditioning.

The drawbar, which can be tightened or loosened at the rear of the spindle, pulls the hardened and ground taper of the arbor into the ground taper seat of the spindle.

**1.** Insert the draw bar into the spindle from the pulley end of the spindle. Pulley cover must be on the lathe before installing the drawbar.

**2.** Insert the tapered end of the arbor into the tapered seat of the spindle. Be certain that the tapers are clean.

**Important:** It is essential that the tapers be thoroughly cleaned. Chips and debris embedded into the arbor or spindle causes poor operation, and will void the warranty.

**3.** Line up witness marks on the arbor and spindle.

**4.** Tighten the arbor onto the drawbar by holding the arbor in place – with witness marks aligned – and tightening the drawbar with a wrench. As the draw bar is tightened, it will pull the tapered adapter end into the tapered seat of the spindle. Tighten to 50 foot pounds.

**Important:** Do not use wrenches or pliers on the arbor shaft to hold it in place. This may chip, scratch, or otherwise damage the arbor.

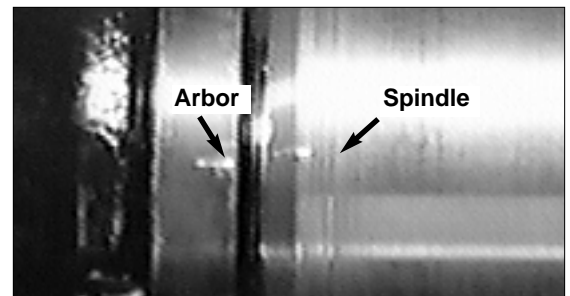

Figure 3 - Witness Marks on Arbor and Spindle

# Brake Lathes

## Mounting Drums

Hubbed drums are mounted with tapered adapters that contact the drum near the middle of the bearing races for accurate mounting. Hubless drums are held in place on the arbor by the hubless adapters and centered by a cone adapter. The hubless adapters should contact the bolt hole surface of the drum while straddling the lug holes if possible.

**Note:** Clean the drum mounting surfaces before mounting the drum. Use a wire brush (or a drill-mounted brush) to clean all mounting surfaces of burrs and rust. The inside diameter of the center hole must be thoroughly cleaned as well. Brush these surfaces down to clean, bare metal to ensure accurate mounting.

After mounting the drum, it may be necessary to use adapters to fill out the arbor so the arbor nut can be tightened down securely. The self-aligning spacer must always be used next to the arbor nut.

1. Determine the correct mounting configuration from the samples shown in Figure 4.
2. Install drum and adapters according to the configuration.
3. Add adapters as necessary to fill the arbor out to the threaded section.
4. Place the self-aligning spacer on the arbor. Tighten the arbor nut either by rotating the drum while holding the nut until they lock up, or by using the wrench to turn the nut until the drum begins to turn, and then continuing to advance the wrench 1/16 of a turn.

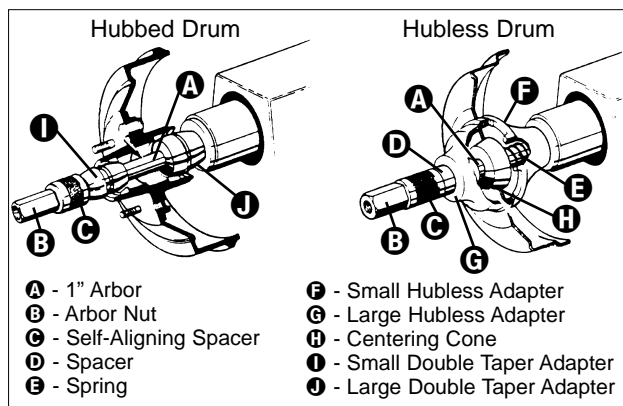

Figure 4 - Typical Drum Mounting Configurations

## Reconditioning Brake Drums

**1.** Before mounting the drum on the lathe, set it on a stable surface and measure the diameter of the brake drum with a brake drum micrometer. Determine if the drum will be within maximum rebore limits after reconditioning. Inspect the drum and verify that it is in good general condition. Remove dirt, rust, and burrs.

**Note:** In most cases, the number cast into the brake drum is the DISCARD diameter, not the maximum MACHINE-TO diameter (which is always less).



Figure 5 - Measure Drum Diameter

**2.** Mount the drum on the arbor using the proper adapters, cones, and spacers. Refer to Figure 4 for mounting instructions and typical mounting configurations.

**3.** If a boring bar is already installed on the lathe, loosen the self-aligning nut slightly to allow for repositioning.

If a twin cutter is installed, remove it and install the boring bar. Hold twin cutter and remove self-aligning nut. Lift twin cutter off lathe. Clean the slide and bottom of boring bar clamp. Install the boring bar and boring bar clamp onto slide, over the T-bolt and secure with self-aligning nut. Handtighten the nut only at this point. Make sure the tool bit is clean and sharp. Replace as necessary to ensure smooth reconditioning.

# Brake Lathes

**Important:** Never position the boring bar clamp so it overhangs the tool slide. This causes the T-bolt to move too close to the edge of the slide. Tightening the self-aligning nut down on the T-bolt in this position can break the T-bolt ways, making the lathe inoperable, damaging the work in process, and creating an unsafe situation.

## CAUTION

**Never operate the lathe with the boring bar clamp or twin cutter mounted to the tool slide so that they overhang the slide. Damage to the lathe and work in process may occur.**

**4.** Position the crossfeed by moving handwheel to rotor position and turning the handwheel clockwise to the “full in” position. Rotate the handwheel counterclockwise a full 2 turns to back the feed out into position.

**5.** Position the tool slide by placing the handwheel in the drum position and turning the handwheel clockwise to move the tool slide to the “full left” position. Turn the handwheel one full turn counterclockwise to position the slide.

**6.** Wrap the drum silencer band snugly around the drum. The band must fully cover the outside of the drum (Figure 8).

**(3860 ONLY)** Turn the end knob of the tool bar counterclockwise until the tool bit is fully retracted.

**7.** Move the boring bar until the tool bit is located in the inside corner of the drum. The tool bit should be next to, but not touching, the drum surface. Tighten the self-aligning nut to 50 foot pounds (a good one-handed pull on the wrench).

**Note:** With the self-aligning nut left loose, the boring bar has 3 inches of travel front-to-back for use in positioning the tool bit.

**8.** Turn the handwheel counterclockwise to move the tool bit to the middle of the drum surface. Rotate the drum by hand and check for clearance all the way around the drum.

## WARNING

**Always wear eye and face protection when working around an operating lathe. Metal chips and fragments may be thrown from a spinning drum or rotor, causing personal injury.**

**9.** Clear lathe and work area of all foreign material, tools and shop rags, then turn lathe on.

**10.** Place crossfeed handwheel into rotor position. Turn handwheel and advance the tool bit until it contacts the drum and makes a scratch cut.

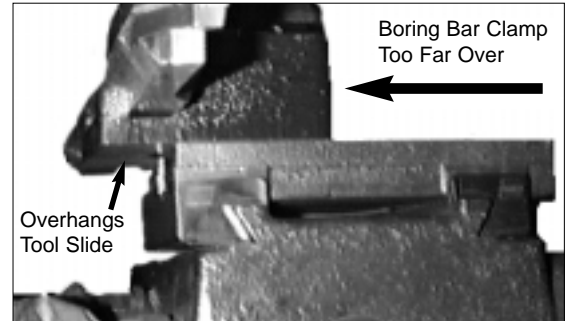

Figure 6 - Improper Boring Bar Mounting



Figure 7 - Drum and Boring Bar Mounted on Lathe



Figure 8 - Wrap Silencer Band Around the Drum



Figure 9 - Positioning the Boring Bar

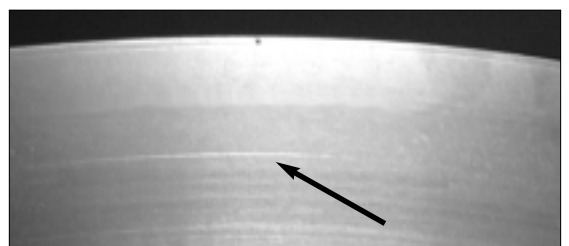

Figure 10 - First Scratch Cut

# Brake Lathes

## MODEL 3850 ONLY (STEPS 11 THRU 21)

**11.** Back the tool bit off, turn the lathe off, and check the drum mounting. Loosen the arbor nut and rotate the drum 1/2 turn (180°) on the arbor. Do not allow adapters to turn with the drum. Retighten arbor nut.

**12.** Place handwheel in drum position and turn handwheel 1/2 turn in either direction. Turn the lathe on, place handwheel in rotor position, advance the tool bit to make a second scratch cut, back the tool bit off, and turn lathe off.

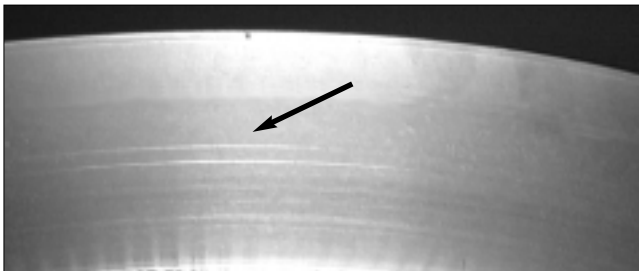

Figure 11 - Second Scratch Cut

If first and second scratch cuts are opposite on another (180° apart), remove the drum from the adapter. Check drum, adapters, and arbor for nicks, burrs, or chips. Clean all mounting parts and surfaces and remount the drum.

If scratch cuts are side by side, mounting is good and the drum is ready for reconditioning.

**13.** Turn lathe on and position the tool bit so it just touches the drum surface. Move handwheel to drum position and turn it clockwise to advance the tool bit to the inside corner of the drum.

**14.** Move handwheel to rotor position and note the number graduation on the handwheel that is aligned with the etched mark on the crossfeed. Rotate the handwheel counterclockwise to dial in the desired depth-of-cut. Cuts may be taken at depths of 0.005 to 0.020 inches (.010 to .040 inches on diameter graduated handwheel).

Determine depth-of-cut setting by adding the desired depth-of-cut to the number graduation aligned with the mark on the crossfeed. For example, if .010 is aligned with the mark, and you wish to make a .020 inch cut, rotate the handwheel counterclockwise until .030 is aligned with the mark.

**Important:** Read and understand the description of Negative and Positive Rake bits on page 3.



**Never operate the lathe with a worn or broken tool bit. This may cause the tool bit holder to contact the drum or rotor surface. The drum or rotor, as well as the tool itself, may be damaged. Replace worn or broken tool bits immediately.**

**Note:** The micrometer depth-of-cut dial is calibrated for drum diameter.

**Important:** Care must be taken to check actual drum diameter before reconditioning so that the maximum rebore limit established by the manufacturer is never exceeded.

**15.** Tighten the crossfeed slide lock knob.

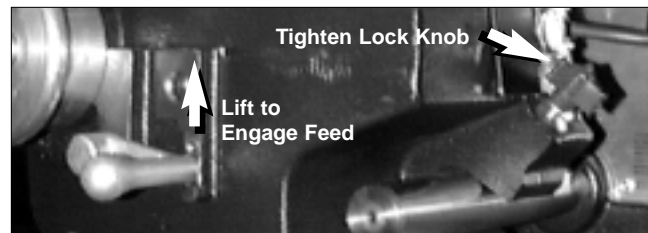

Figure 12 - Lock Slide and Engage Feed

**16.** Place the handwheel in the drum feed position.

**17.** Lift engagement lever to engage the drive and begin the cut.

**18.** When the tool bit clears the outer edge of the drum surface, push the engagement lever down to stop the feed.

**19.** Turn the lathe off and inspect the drum. Do not remove the drum from the lathe.

**20.** If the first cut has not cleaned the entire brake surface, leave the tool bar locked in position. Turn the lathe on and slowly turn the handwheel clockwise to move the tool bit back into the drum. Advance until the tool bit touches the bottom of the drum and scrapes. Turn the handwheel counterclockwise until the scraping stops. Repeat steps 14 through 19.

**21.** Remove the reconditioned drum, spacers, and adapters from the lathe. Clean metal and cutting debris from the adapters, spacers, arbor, and lathe.

# Brake Lathes

## MODEL 3860 ONLY (STEPS 11 THRU 21)

**11.** Back the tool bit off, turn the lathe off, and check the drum mounting. Loosen the arbor nut and rotate the drum 1/2 turn (180°) on the arbor. Do not allow adapters to turn with the drum. Retighten arbor nut.

**12.** Turn handwheel 1/2 turn in either direction. Turn the lathe on, advance the tool bit to make a second scratch cut, back the tool bit off, and turn lathe off.

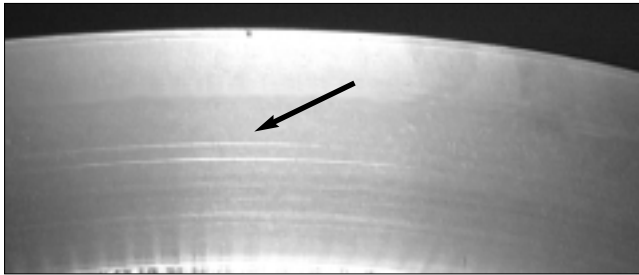

Figure 11 - Second Scratch Cut

If first and second scratch cuts are opposite on another (180° apart), remove the drum from the adapter. Check drum, adapters, and arbor for nicks, burrs, or chips. Clean all mounting parts and surfaces and remount the drum.

If scratch cuts are side by side, mounting is good and the drum is ready for reconditioning.

**13.** Turn lathe on and position the tool bit so it just touches the drum surface. Turn clockwise to advance the tool bit to the inside corner of the drum.

**14.** Tighten the crossfeed slide lock knob.

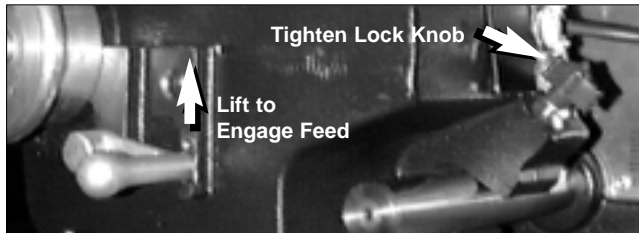

Figure 12 - Lock Slide and Engage Feed

**15.** Hold the end knob of the tool bar micrometer still, and turn the inner dial to zero.

Cuts may be .002"—.010" deep. A rough cut should be no more than .010", a finish cut should be no less than .002".

A cut of .002" from an 8" drum will result in a refinished diameter of 8.004".

**Note:** A round, smooth, flat drum may require only a finish cut .002"—.004" deep.

**16.** Turn the end knob of the tool bar micrometer clockwise to set the tool bit to the desired depth-of-cut (not more than .010" deep).

**Important:** Read and understand the description of Negative and Positive Rake bits on page 3.



**Never operate the lathe with a worn or broken tool bit. This may cause the tool bit holder to contact the drum or rotor surface. The drum or rotor, as well as the tool itself, may be damaged. Replace worn or broken tool bits immediately.**

**Important:** Care must be taken to check actual drum diameter before reconditioning so that the maximum rebore limit established by the manufacturer is never exceeded.

**17.** Lift engagement lever to engage the drive and begin the cut.

**18.** When the tool bit clears the outer edge of the drum surface, push the engagement lever down to stop the feed.

**19.** Turn the lathe off and inspect the drum. Do not remove the drum from the lathe.

**20.** If the first cut has not cleaned the entire brake surface, leave the tool bar locked in position. Turn the lathe on and slowly turn the handwheel clockwise to move the tool bit back into the drum. Advance until the tool bit touches the bottom of the drum and scrapes. Turn the handwheel counterclockwise until the scraping stops. Repeat steps 16 through 19.

**21.** Remove the reconditioned drum, spacers, and adapters from the lathe. Clean metal and cutting debris from the adapters, spacers, arbor, and lathe.

# Brake Lathes

## Mounting Brake Rotors

Before mounting, each rotor should be carefully inspected for scoring, rust ridges, and hard spots. Carefully note any excessive wear or deformity. If rotor is not within acceptable limits, do not attempt to service it; rotors of this type should be replaced.

Use the typical rotor mounting configurations provided here as a guide.

Figure 13 - Typical Rotor Mounting Configurations

- A** - 1" Arbor
- B** - Arbor Nut
- C** - Self-Aligning Spacer
- D** - Spacer
- E** - Spring
- F** - Small Hubless Adapter
- G** - Large Hubless Adapter
- H** - Centering Cone
- I** - Small Double Taper Adapter
- J** - Large Double Taper Adapter
- K** - Adapter, Used as Spacer

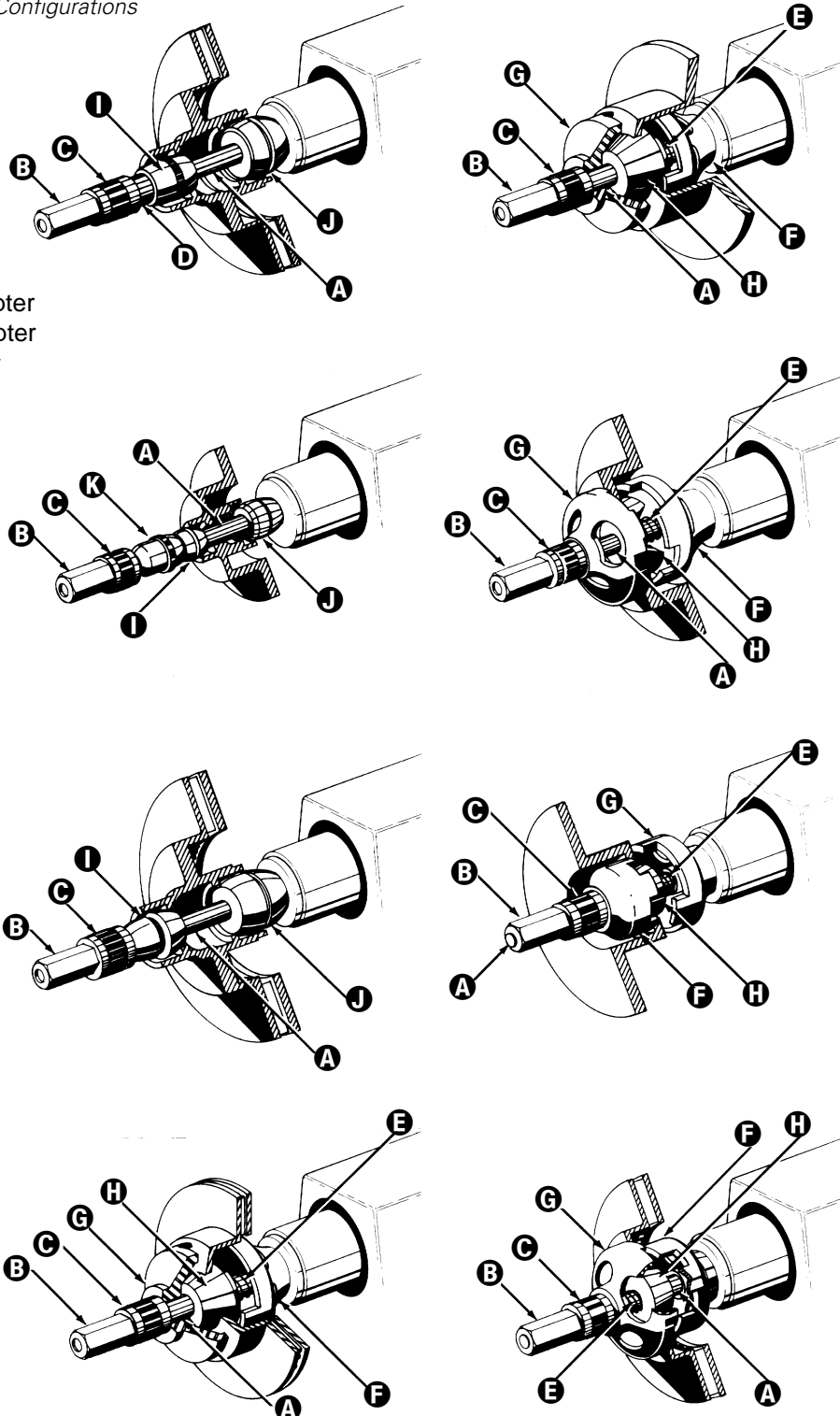



# Brake Lathes

## Reconditioning Brake Rotors

**1.** Mount the rotor. Use the typical mounting configurations in Figure 13 as a guide.

**2.** If a twin cutter is already installed on the tool slide, Loosen – but do not remove – the self-aligning nut to allow the cutter to move on the slide. Rotate the cutter counterclockwise (as viewed from above) to move the tool bits away from the rotor and arbor.

If a boring bar is in place, remove it. Place the twin cutter on the feed with the T-bolt extending through the slot in the top and the tool bits positioned away from the rotor. Thread the self-aligning nut onto the T-bolt and tighten only enough to hold the cutter on the slide.

**Important:** Never position the twin cutter so it overhangs the tool slide. This causes the T-bolt to move too close to the edge of the slide. Tightening the self-aligning nut down on the T-bolt in this position can break the T-bolt ways, making the lathe inoperable, damaging the work in process, and creating an unsafe situation.

**3.** Place the handwheel in the rotor position. Turn the handwheel clockwise to move the feed to the “full in” position. Turn the handwheel counterclockwise 2 full turns to back the feed out into position.

**4.** Place handwheel in drum position. Turn the handwheel clockwise to move the tool slide to the “full left” position. Turn the handwheel counterclockwise 2 full turns to back the slide out into position. Tighten the red lock knob on the front of the tool slide.

**5.** Use a micrometer to check the thickness of the rotor at no less than 3 points around the circumference of the rotor. Take the measurements about 1” (2.54 cm) in from the outside edge.

If the thickness varies between readings, the rotor should be machined. However, if the thickness is less than the minimum established by the vehicle manufacturer, or if reconditioning would bring the thickness down to less than the minimum, the rotor should be replaced.

**Important:** In most cases, the thickness cast or stamped into the rotor is the DISCARD thickness, not the minimum MACHINE-TO thickness.

**6.** Attach the silencer band to the rotor. Stretch the band evenly around the rotor and hook the metal loop over a lead weight on the band. Make sure it fits snugly around the rotor and is hooked securely to prevent accidental release of the band during lathe operation.

**7.** Loosen the tool bit lock knobs on the twin cutter and fully retract both tool bits by turning the knobs on the cutter counterclockwise.

**8.** Move the crossfeed in towards the lathe and center the cutter so the rotor is between the tool bits. As long as the self-aligning nut is not fully tightened, the cutter has enough room to move and align with the rotor properly without moving the feed or tool slide. Tighten the self-aligning nut to 50 foot pounds after cutter is positioned.



Figure 14 - Mounted Rotor and Initial Twin Cutter Position

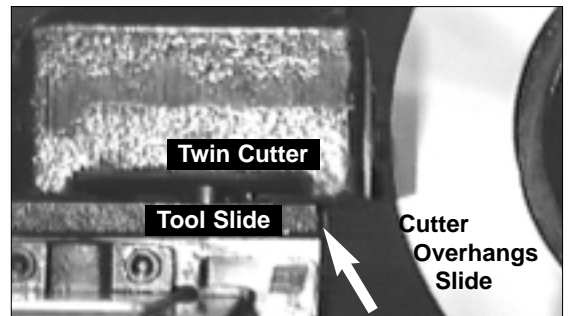

Figure 15 - Improper Twin Cutter Mounting

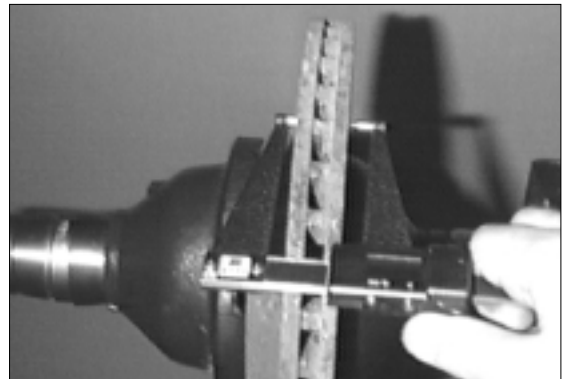

Figure 16- Measure the Thickness of the Rotor



Figure 17 - Attach Silencer Band

# Brake Lathes

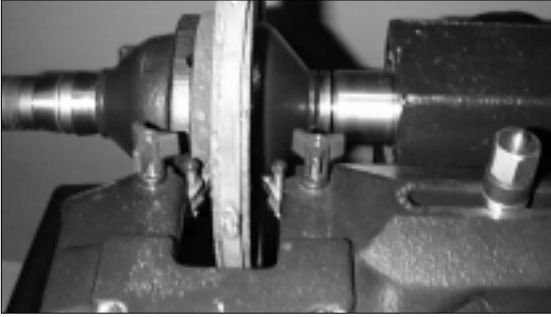

Figure 18- Positioning Cutter Around Rotor

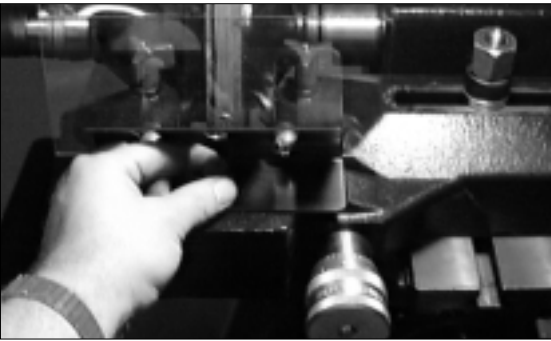

Figure 19 - Mounting the Safety Shield



Figure 20 - Adjusting Depth-of-Cut Collar



Figure 21- First Scratch Cut

**Note:** Be sure to position twin cutter so the outside tool bit will be able to just barely contact the rotor hat and the inside tool bit will clean the entire surface.

## CAUTION

**Do not operate the lathe with twin cutter without safety shield in place. It helps protect the operator and bystanders from the metal chips and debris that fly out from the cutter during machining. These chips and cuttings may cause personal injury. Review the safety instructions at the beginning of this manual before proceeding.**

**9.** Place the safety shield in position on top of the twin cutter (if not already installed). Locate the thumb screw into the hole in the twin cutter and tighten securely. Move shield down into operating position.

**10.** Turn the tool bit knobs and advance the bits in until they are next to, but not touching, the rotor surface.

## WARNING

**Safety glasses, safety goggles, or face shields must be worn during the reconditioning process. Put them on before starting the lathe.**

**11.** Make sure work area is clear. Turn the lathe on.

**12.** Turn a tool bit control knob clockwise to advance the tool bit into the rotor. Move it in until it just touches the rotor surface.

**13.** Turn the depth-of-cut collar on the tool bit to zero, and back the tool bit away from the rotor.

**14.** Repeat steps 12 and 13 for the other tool bit.

**Important:** From this point on, all tool adjustments will be made with the tool bit controls. The depth-of-cut collars will be the reference and should not be moved.

**15.** Place the handwheel in the rotor position. Turn the handwheel counterclockwise and move the twin cutter in until the tool bits are approximately at the mid point of the rotor surface.

**16.** Turn the left tool bit knob until the tool bit contacts the rotor surface and makes a scratch cut. Back the tool bit away and turn lathe off.

**Note:** The scratch will usually appear as an incomplete circle around the rotor. This is caused by runout or wobble due to rotor condition or improper rotor mounting.

**17.** Loosen the arbor nut and turn the rotor 180° on the adapters. Do not allow the adapters to rotate along with the rotor. Retighten the arbor nut.

**18.** Turn the handwheel counterclockwise a half turn to move the tool bit away from the first scratch cut.

# Brake Lathes

**19.** Turn the lathe on and move the tool bit in to the rotor and make a second scratch cut. Back the tool bit away and turn lathe off.

**20.** Inspect the scratch cuts.

If the cuts are side by side, the runout or wobble is caused by the rotor condition. Use a dial indicator to compare rotor runout with manufacturer's specifications.

If the cuts are opposite each other (180° apart), the rotor may not be mounted correctly. Remove the rotor and examine the adapters for nicks, burrs, chips, dirt, or rust. Inspect the rotor hub for loose or damaged bearing cups. Clean, repair, remount, or replace as necessary.



Figure 22 - Second Scratch Cut

**21.** Recheck the depth-of-cut collars that were set to zero earlier. To compensate for runout, turn the lathe on and move the tool bits in until they just just scribe a line around the entire diameter. Depth-of-cut collars should read zero. Reset as necessary.

**22.** Back the tool bits away from the rotor and turn the lathe off. Turn the handwheel clockwise and move the tool bits in towards the rotor hub.

**Remember:** The outside tool bit should reach all the way in to just barely touch the rotor hat and the inside tool bit should be positioned to clean the entire inner surface.



**Safety glasses, safety goggles, or face shields must be worn during the reconditioning process. Put them on before starting the lathe.**

**23.** Turn the lathe on. Use the handwheel in rotor position to advance the outer tool bit in towards the rotor to clean the rotor hat. Back the handwheel off a half turn after hat is cleaned.

**24.** Dial both tool bit control knobs to zero and then dial in an additional .005 inch minimum for positive

rake bits and .002 inch for negative rake bits depth-of-cut. Lock them in place with the red lock knobs.

**Important:** Read and understand the description of Negative and Positive rake bits on page 3.



**Never operate the lathe with a worn or broken tool bit. This may cause the tool bit holder to contact the drum or rotor surface. The drum or rotor, as well as the tool itself, may be damaged. Replace worn or broken tool bits immediately.**

**25.** Pull the engagement handle up to engage the feed drive and move the tool bits outward across the rotor surfaces. When the tool bits clear the edge of the rotor, disengage the feed drive, turn the lathe off and inspect the surfaces.

**26.** If either surface has not been completely reconditioned by this first cut, reposition the tool bits near the rotor hub, select new depth-of-cut, and make a second cut across the rotor.



**Keep rags and loose clothing away from an operating lathe. Never wear gloves when operating a lathe. These items may become entangled in the arbor or spindle and pull the operator into the lathe, causing personal injury.**



**Never operate the lathe without the pulley cover securely in place over the drive belt and pulleys. Operating the lathe without this cover in place may cause personal injury.**

# Brake Lathes

## Maintenance and Service

All the caution, warning, and danger information, as well as the general safety information contained in this manual must be observed not only during lathe operation, but while performing maintenance and service items too.

Proper maintenance and service is required to keep this unit operating in a safe and efficient manner. In addition to the specific maintenance items that are listed here, the following general maintenance items must also be done regularly:

- 1.** Check all fasteners and keep them tight.
- 2.** Check all electrical components for proper, tight connections. Check wiring for exposed wires or damaged connectors.
- 3.** Check all safety equipment and components. Verify that each item is in place or available for use as described in this manual.
- 4.** Check all instructional and warning information labels and plates on the unit and make sure they are properly attached and clearly visible.
- 5.** Fix or replace any damaged or excessively worn components.



**Keep rags and gloves used during maintenance and service away from the lathe when procedures require turning the lathe on. They may become entangled in the arbor or spindle, and pull the operator into the lathe causing personal injury.**

## Lubrication

The bare metal parts are coated with an oil-soluble rust preventative. It is not necessary to clean the rust preventative from these parts. Before using the lathe, all bare metal parts should be wiped down with an oiled rag. Use a light machine oil for the initial and daily wipe downs. Do not oil the tool bar clamping surfaces on top of the slides.

**A.** Use a soft bristled brush to clear away metal chips and debris before lubricating parts.

**B.** Grease crossfeed and rotor lead screw with a hand grease pump monthly. Grease fittings (2) are provided.

**Note:** Crossfeed should be in the fully inward position during lubrication.

**C.** Lubricate the 1 inch drum lead screw monthly. Apply a light coating of Motor Kote 100 to the lead screw.

**D.** Keep the dovetail ways lightly oiled.

# Brake Lathes

## Cleaning

Keep the lathe and the immediate working area as clean as possible for trouble-free operation as well as safety and longer lathe life. Use a soft bristled brush to keep metal chips and dust off the lathe.



**Do not use compressed air to blow the lathe clean. Chips and dust may be driven into the air with enough force to cause personal injury. Chips and dust may also be driven between machined parts, causing undue wear and voiding the warranty.**



**Always brush metal chips, dirt and debris away from the operating areas of the lathe. Do not brush chips or debris onto the motor, into the belt or pulleys, or onto tool slide ways. Lathe performance and service life can be adversely affected and other damage may occur.**

**A.** Use a soft bristled brush to wipe dust and chips from the tool slide clamping surfaces before installing boring bars or cutters.

**B.** Use a shop vac to help keep the lathe and bench area clean of metal chips, dirt and debris that can damage the lathe and affect performance. Dispose of the material properly.

## Arbor and Adapter Care

**Important:** Although the adapters, arbors, and spindle are made of top grade steel, great care should be taken in their use, handling, and storage. Even the smallest nick, scratch, or loose chip can cause incorrect rotor or drum alignment, resulting in inaccurate machining.

**A.** Remove all adapters from the arbor after machining a drum or rotor and wipe them clean. Pay particular attention to the inboard adapter. When a finished drum or rotor is removed from the arbor, the inboard adapter may move slightly away from the face of the arbor and allow metal chips to fall into the opening causing a poor mounting for the next drum or rotor.

**B.** Regularly inspect the faces and seating tapers of the adapters for nicks and scratches. Correct any flaw with a fine stone. If the damage cannot be corrected, replace the adapter. Handle the adapters and arbors with care and store them on individual hooks. Do not throw them in a box. The adapters are designed for mounting drums and rotors only. Do not misuse the adapters.

# Brake Lathes

## Gib Adjustment

Accurate gib adjustment is required for smooth and accurate operation.

Gib adjustment requires patience and time. A "rushed" gib adjustment will result in poor lathe performance, poor reconditioning, reduced tool life, and other long-term lathe problems. The gib is adjusted at the factory and should only require adjustment for wear after long periods of use.

**1.** If a twin cutter is mounted to the lathe, remove it now.

**2.** Install the boring bar on the tool slide. Position the boring bar perpendicular to the lathe spindle (pointing away from the lathe).

**Note:** These instructions will use the boring bar as a lever during gib adjustment. By lifting up on the boring bar, any movement in the gibs will be amplified for easier identification and correction.

**3.** Secure the boring bar with the self-aligning nut. Tighten self-aligning nut securely.

**4.** Place the handwheel in drum position.

**5.** Fully loosen the red lock knob on the front of the tool slide.

**6.** Securely tighten the red lock knob on the crossfeed tube (on the lower right of the crossfeed assembly).

**Note:** This will eliminate any movement in the crossfeed gibs. Crossfeed gib movement will interfere with the detection and correction of looseness in the tool slide gibs.

**7.** Position the tool slide squarely on the gibs. It must not overhang the gibs at either end.

**8.** Check for looseness in the tool slide by pushing up and down on the boring bar. If looseness is detected, continue to step 9. If no looseness is detected, continue to step 13 for crossfeed gibs.

**Note:** The boring bar will amplify the looseness in the gibs to make it easier to find and correct.

**9.** Loosen the jamb nuts on the front of the tool slide with a 1/2 inch wrench.

**10.** Adjust the set screws inside the jam nuts until the looseness is eliminated and the tool slide moves smoothly with only moderate force. Use a 5/32 inch allen wrench on the set screws.

**Note:** Check for tool slide looseness by pushing up and down on the boring bar. Check this frequently while adjusting the set screws.

**Note:** Check the movement of the tool slide by turning the handwheel to the left and right. The tool slide should move smoothly with only moderate effort required to turn the handwheel.

**11.** Once looseness is eliminated and the tool slide moves smoothly, hold the set screws in place with the allen wrench and tighten the jam nuts down securely with the 1/2 inch wrench.

**12.** Recheck the tool slide for looseness and smooth movement. Adjust again if looseness is felt or tool slide movement is jerky or difficult.

**Note:** If the tool slide jerks or more than a moderate amount of effort is required to turn the handwheel, the adjustment is too tight.

**13.** Loosen the self-aligning nut and turn the boring bar counterclockwise. The tool bit must be pointing towards the belt cover on the lathe.

**14.** Tighten the self-aligning nut down securely.

**15.** Lock down the tool slide by tightening the red lock knob down securely.

**16.** Place handwheel in rotor position.

**17.** Remove the red lock knob on the crossfeed tube.

**18.** Check the crossfeed for looseness by pushing up and down on the boring bar. If looseness is felt, continue to step 19. If no looseness is felt, no further adjustment is required (go to step 24).

**19.** Loosen the jam nut next to the red lock knob (removed in step 17) with a 9/16 inch wrench.

**20.** Tighten the set screw in the middle of the jam nut with a 3/16 inch allen wrench.

**21.** Recheck looseness by pushing up on the boring bar. If looseness is still present, continue tightening down on the set screw.

**22.** Once looseness has been corrected, hold the set screw in place with the 3/16 allen wrench and tighten the jam nut down with the 9/16 inch wrench.

**23.** Check for smooth crossfeed movement by turning the handwheel left and right. Adjust again if the movement is jerky or difficult.

# Brake Lathes

**Note:** If the crossfeed jerks or more than a moderate amount of effort is required to turn the handwheel, the adjustment is too tight.

**24.** Thread the red lock knob back into the hole on the side of the crossfeed.

**25.** Remove the boring bar. The lathe is now ready to be returned to service.



**Follow all posted shop rules during maintenance, service and repair activities. Failure to follow posted rules (such as lock-out and tag-out procedures) may cause personal injury or equipment damage.**

## 3860 Drum Tool Bar Adjustment

**1.** Turn the micrometer dial counterclockwise to unscrew the dial from the boring bar. Remove the micrometer dial assembly.

**2.** Unscrew the two (2) allen head cap screws from the tool holder end of the tool bar. Press the tool holder against a solid stop, pull the screws from the boring bar and carefully ease the bar away from the stop.

**3.** Clean all metal chips and dirty grease from all the working parts.

**4.** Slip the spring into the bore of the tool bar. Grease the sleeve with white grease and slip it into the bore of the tool bar.

**5.** Slip the tool holder between the ears of the boring bar, press the tool holder against a solid stop and insert the allen head cap screws. Run the screws all the way in.

**6.** Insert the micrometer dial assembly into the tool bar and screw the micrometer all the way in.

**7.** Fully tighten one (1) of the allen head cap screws, then back the micrometer dial out two (2) turns.

**8.** Slowly loosen the allen head cap screw until the tool holder slips back.

**9.** Screw the micrometer all the way in and repeat steps 7 and 8 for the other allen head cap screw.

