

SBM 800 s

***PARTI DI DICAMBIO
PIÈCES DE RECHANGE
SPARE PARTS
ERSATZTEILEN
REPUESTOS***

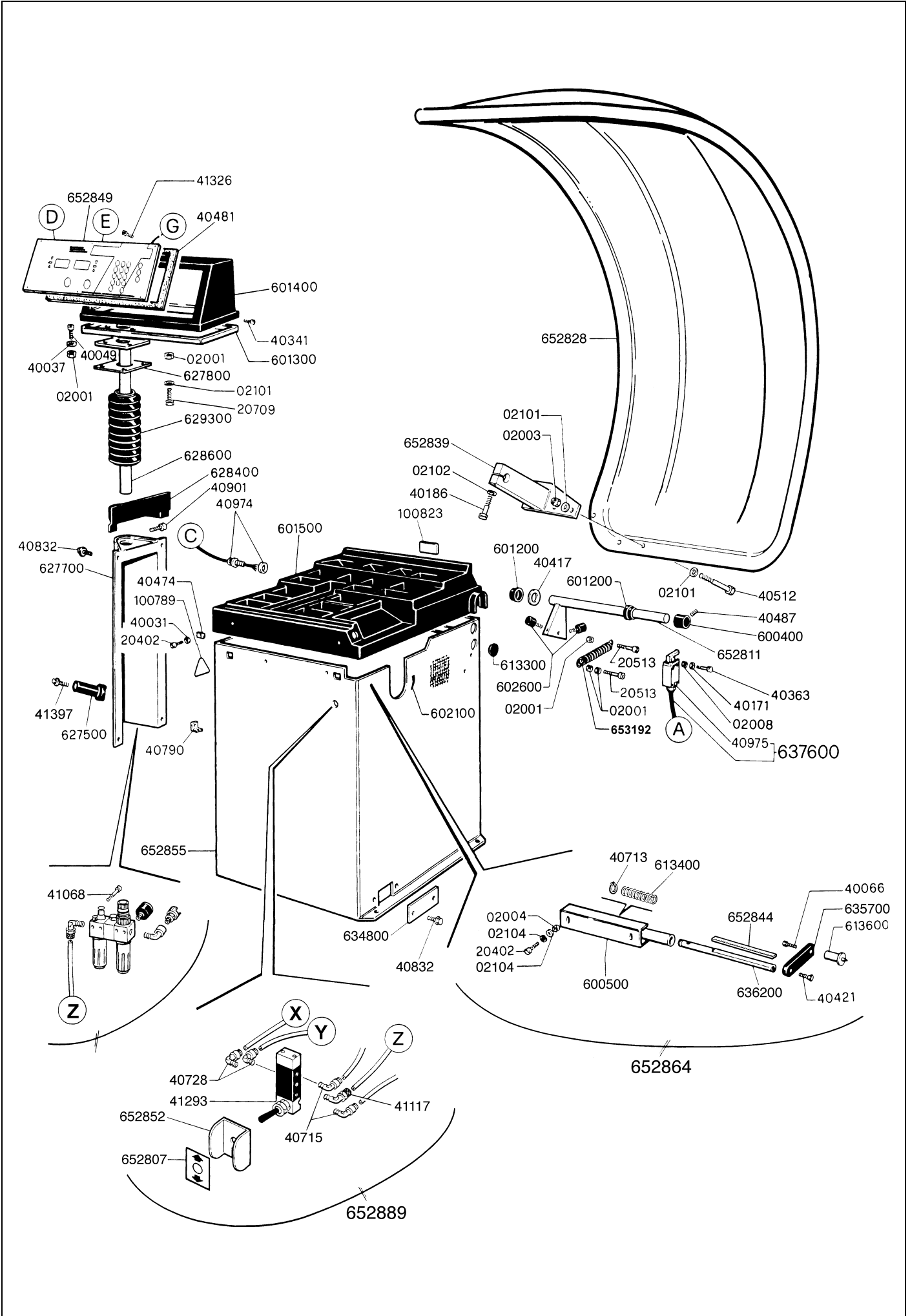

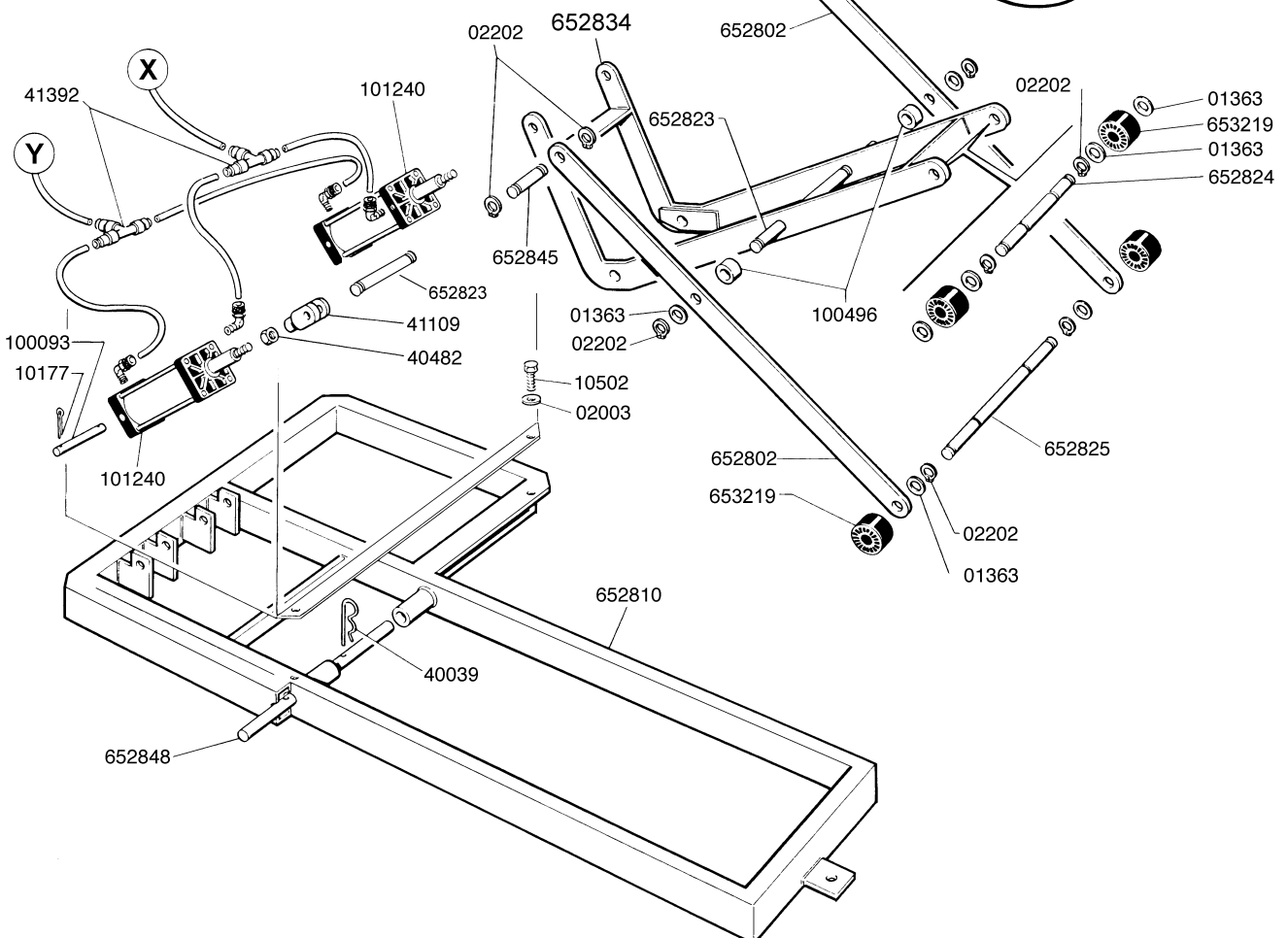
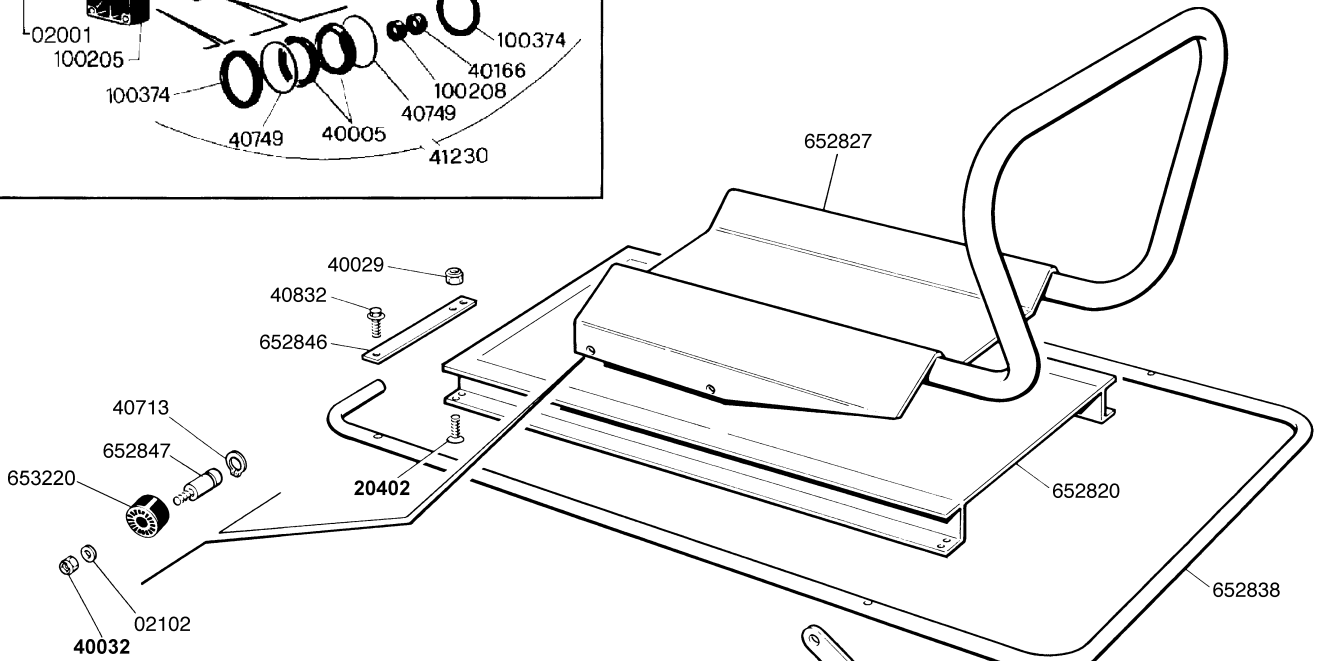
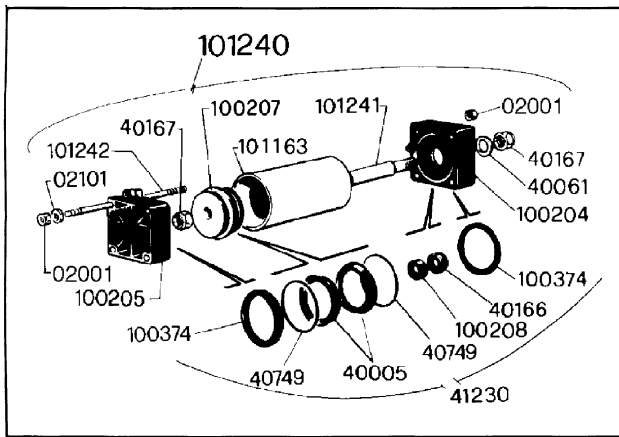

SCHEMA ELETTRICO EQUILIBRATRICE SBM 800s A 230V
SBM 800s BALANCING MACHINE ELECTRIC DIAGRAM AT 230V
DIAGRAMA DE CONEXION BALANCEADORA SBM 800s A 230V

CABLE PER IMPIANTO ELETTRICO 10x0,5
 CABLE FOR ELECTRICAL POWER BOARD 10x0,5

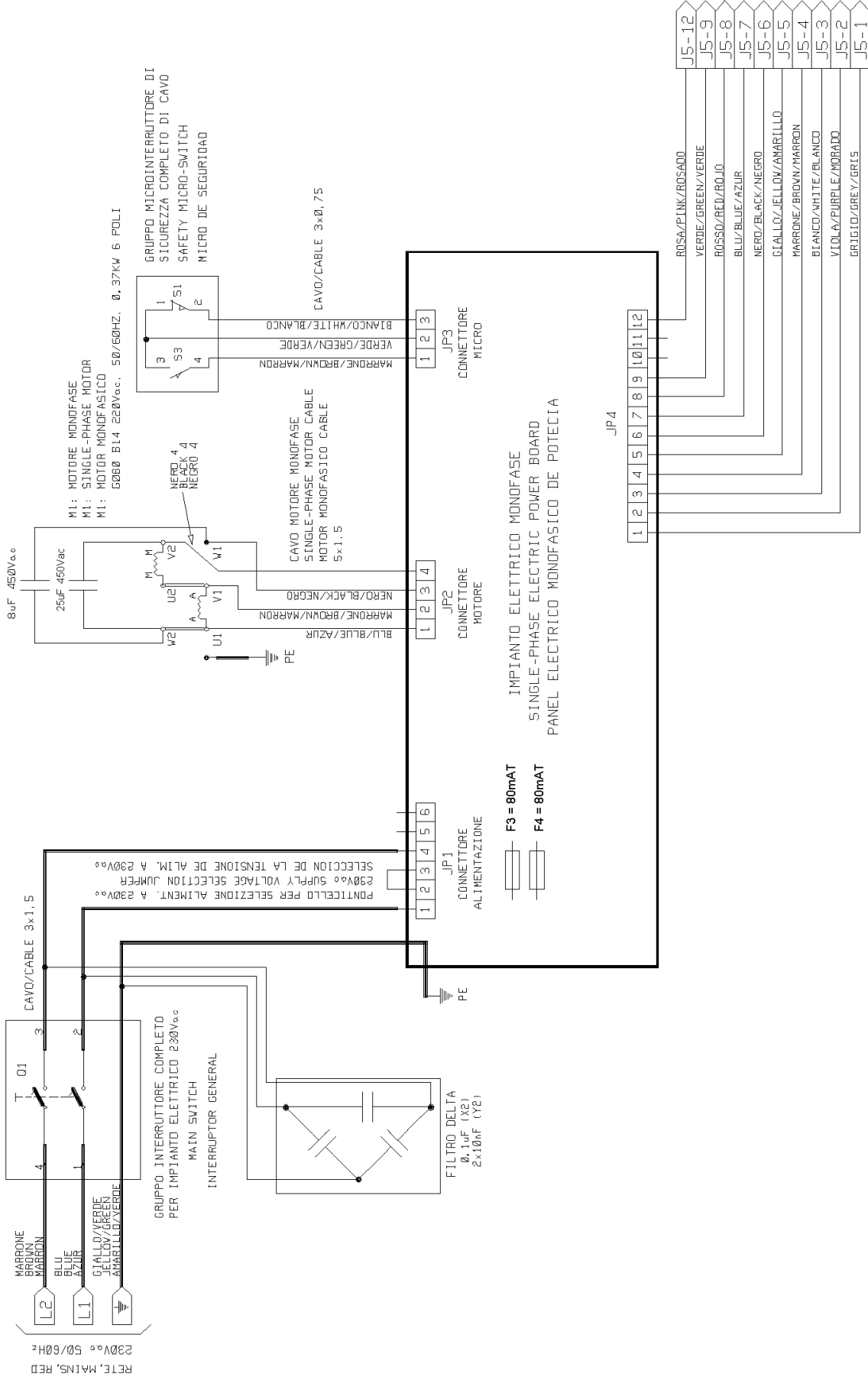

SCHEMA ELETTRICO EQUILIBRATRICE SBM 800s A 230V
SBM 800s BALANCING MACHINE ELECTRIC DIAGRAM AT 230V
DIAGRAMA DE CONEXION BALANCEADORA SBM 800s A 230V

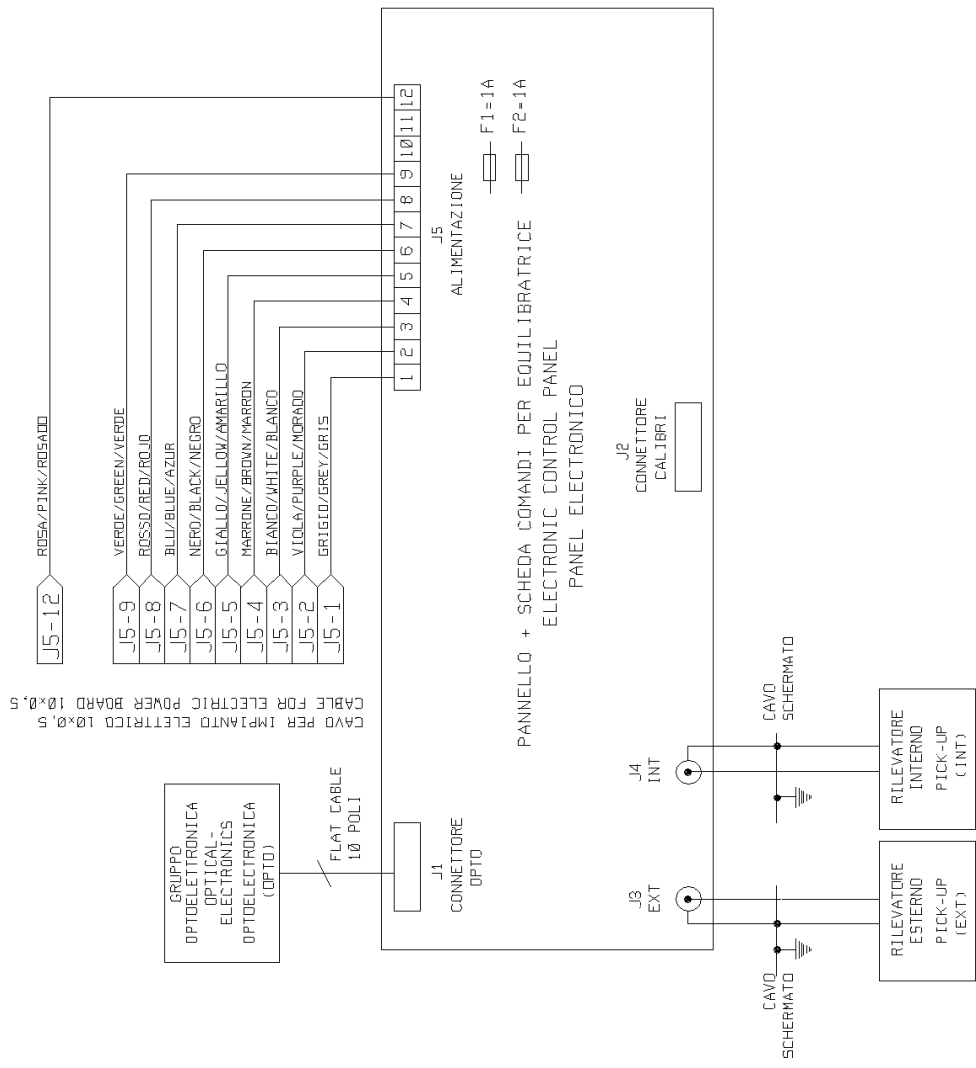



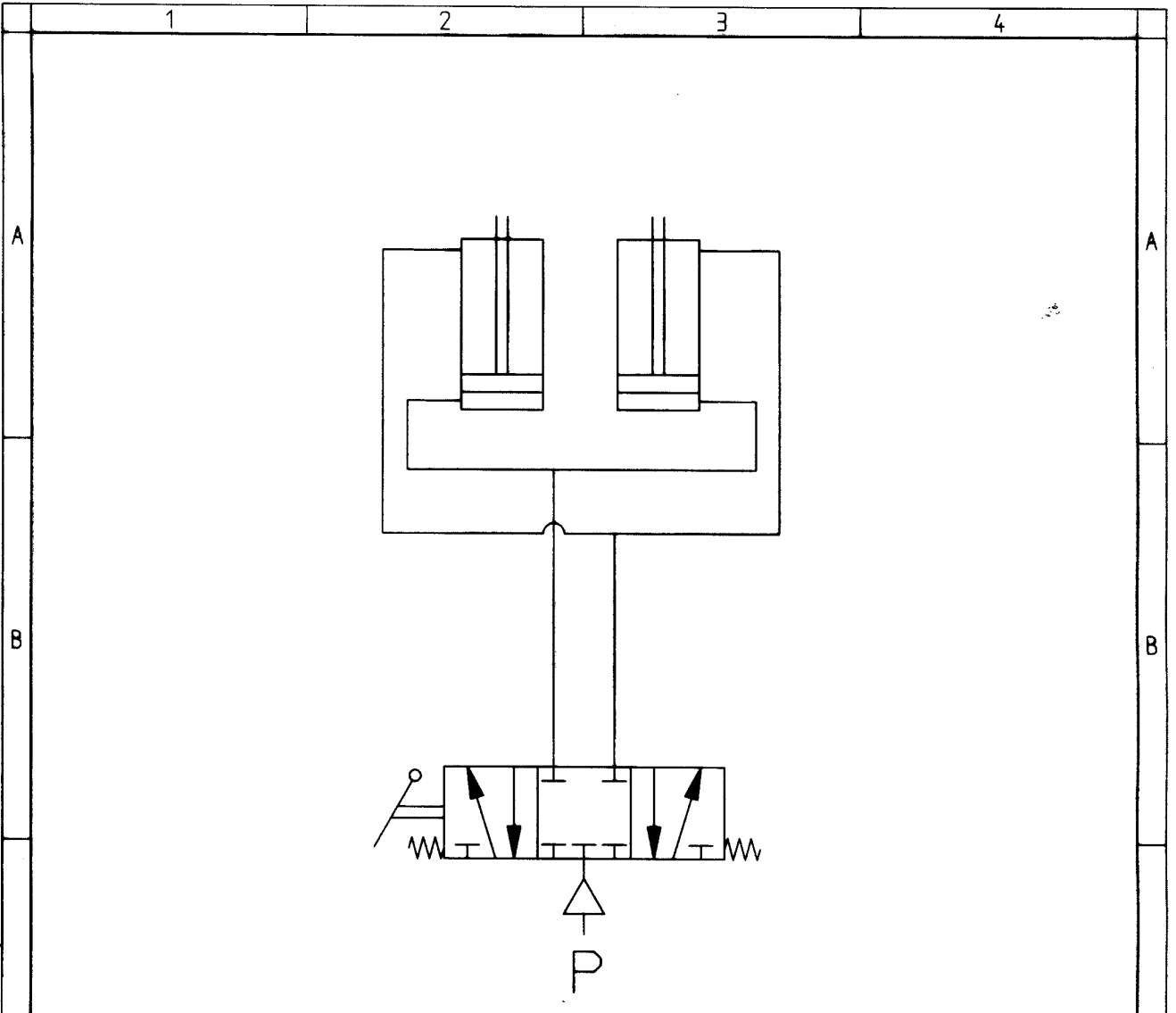

4							
3							
2							
1							

Rev. N°	Data	Descrizione revisione		Disegnato	Controllato	Approvato	Rif. richiesta di modifica
Disegnato	Data	Controllato	Data	Approvato	Data		
Bartoli Pietro	10/11/1998	Bartoli Pietro	10/11/1998	Magnani Franco	10/11/1998		
Materiale		grezzo - Peso Kg - finito		Stato e dim. del grezzo			
Rivestimento Sup.		Trattamento sup.		Prof.tratt. mm		Dur. HRC	

 CORREGGIO (RE)	Quote senza indicazione di tolleranza:	Codice <u>652890</u>
	Denominazione <u>Schema pneumatico sollevatore per equilibratrice</u>	Q.ta' _____
	Gruppo <u>Sollevatore per equilibratrice</u>	Scala _____

Z:\DWG\PROTOTIP\PROGETTO 007\Schema pneumatico